

PUBLIC ADDRESS / ATTENUATORS / 100 V LINE

DOT-12TR

100 V LINE ATTENUATOR



- ✓ 100 V line
- ✓ Priority by 3 or 4 wires with relay
- ✓ For universal standard case
- ✓ 10 position ergonomic potentiometer with switch off
- ✓ Minimalist aesthetic

ESPECIALLY RECOMMENDED IN:



All sectors



+ Info:
<https://fonestar.com/DOT-12TR>

DESCRIPTION

100 V line attenuator with 3- or 4-wire priority with relay for recessed or surface mounting.

FONESTAR's own minimalist design, taking into account the market's demand for a device that will go unnoticed in any kind of installation, be it household or professional in nature.

Ergonomically designed 10-position potentiometer with off switch, allowing for easy handling.

Offers 2-wire input, and 3- and 4-wire for 24 V systems with priority. As a result, they are perfect for issuing priority messages throughout large-scale installations.

The standard measurements allow them to be installed in universal square or round boxes of cardboard and plaster partitions (Pladur). Also able to be installed on surfaces, together with the DOT-BOX surface installation boxes, available in black or white.

This entire range is available in white; however, for installations requiring black attenuators, the black panel mod. DOT-01N can be purchased separately, and is easily interchangeable with the white one.

PA and voice evacuation systems, large and small commercial establishments, shopping centres, hotels, cafeterias, game rooms, home use, etc.

TECHNICAL CHARACTERISTICS

FEATURES	100 V line attenuator with autotransformer for recessed or surface mounting 2-wire input and 3- and 4-wire priority systems (24 V).
POWER	12 W maximum
INPUTS	High Z 100 V line
OUTPUTS	High Z 100 V line
CONTROLS	10 attenuation positions and off switch
DIMENSIONS	Total: 83 x 83 x 50 mm depth Insert: 50 x 50 x 38 mm depth
WEIGHT	0.15 kg



+ Info:

<https://fonestar.com/DOT-12TR>

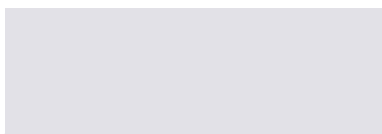

For standard universal square box, round for plasterboard partitions and for surface installation box mod. DOT-BOX.

Distance between screws: 60 mm



+ Info:

<https://fonestar.com/DOT-12TR>

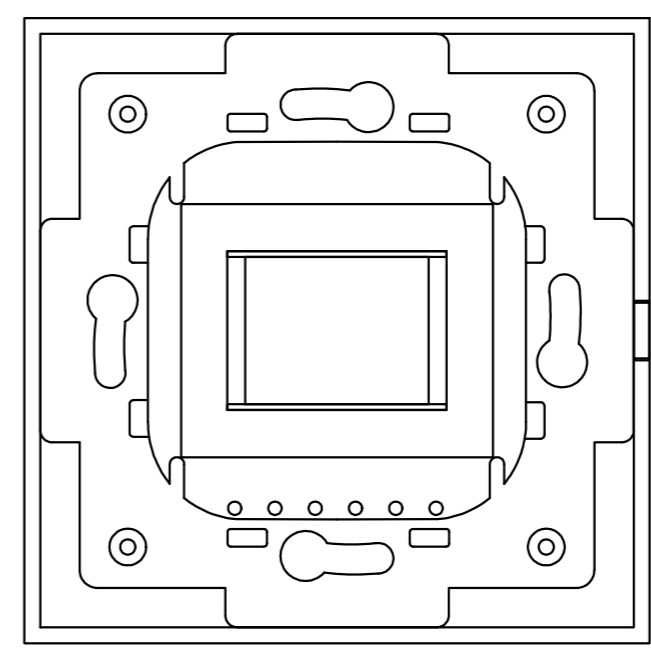
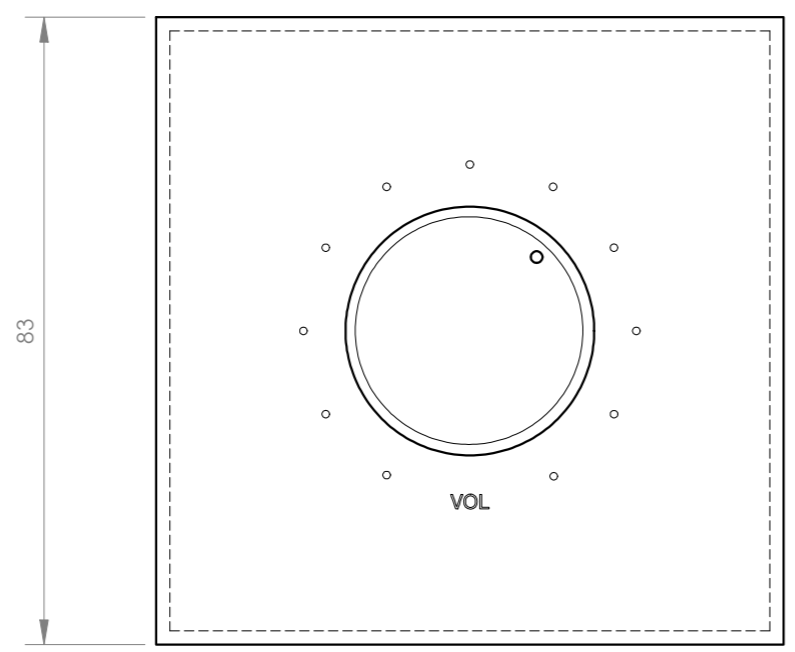
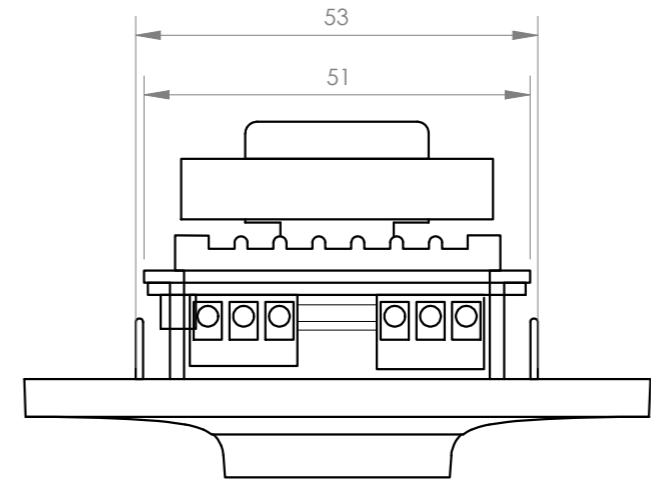
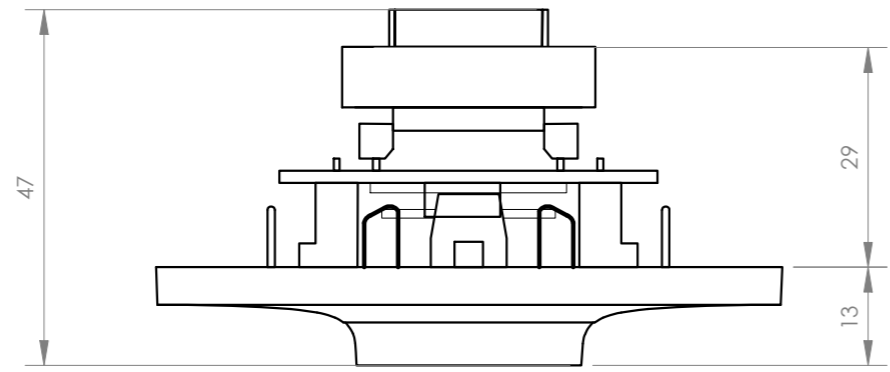

FONESTAR	Model	Description	Units	Scale
	DOT-12TR	100 V LINE ATTENUATOR	mm	1:1