

HIGH POWER / LOUDSPEAKERS / PASSIVE

FORCE-12

PASSIVE HIGH-POWER LOUDSPEAKER.



- ✓ High power with rich sound
- ✓ Robust structure and high quality components
- ✓ Carrying handles, suspension points and hole in base for 35 mm tube
- ✓ User-friendly and intuitive

ESPECIALLY RECOMMENDED IN:



All sectors



+ Info:
<https://fonestar.com/FORCE-12>

DESCRIPTION

High power loudspeaker

FONESTAR has developed the FORCE high power loudspeaker range.

Speakers that deliver a powerful sound with great detail, specially designed for portable or fixed sound systems. They feature a heavy-duty injection case with handles for easy and safe transport and high-quality components.

Excellent grain paint finish.

Suspension points and hole in base for 35 mm tube for suspension or stand installation.

Front metal grille ensures speaker integrity.

Perfect for disco-mobile applications, discos, pubs, gyms, restaurants, events or parties, etc.

TECHNICAL CHARACTERISTICS

FEATURES	High power loudspeaker. Injection-moulded case. Textured paint finish. Carrying handles and suspension points. Hole in the base for 35 mm tube.
POWER	800 W peak, 300 W RMS
LOUDSPEAKERS	1 x 12" woofer: 65 mm coil and 156 mm ferrite magnet 1 x 1" compression driver: 34 mm coil and 90 mm magnet
RESPONSE	55-20,000 Hz
IMPEDANCE	8 Ohm
SENSITIVITY	97 dB at 1 W/1 m
SOUND PRESSURE	123 dB at maximum power at 1 m



+ Info:

<https://fonestar.com/FORCE-12>

DISPERSION	90° H x 90° V
CONNECTORS	2 x 4-contact loudspeaker connectors (1+, 1-)
CROSSOVER	Passive, 2 way Crossover frequency 2,500 Hz, -9 dB/octave
SUSPENSION POINTS	5 M8 points
COLOUR	Black
DIMENSIONS	380 x 595 x 370 mm depth
WEIGHT	17.5 kg



+ Info:

<https://fonestar.com/FORCE-12>

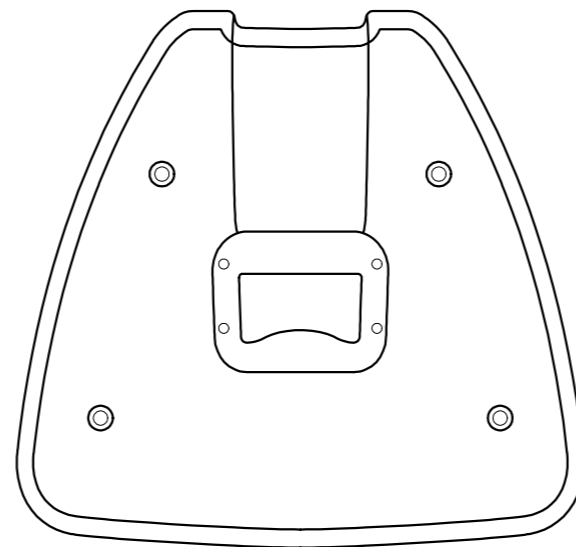
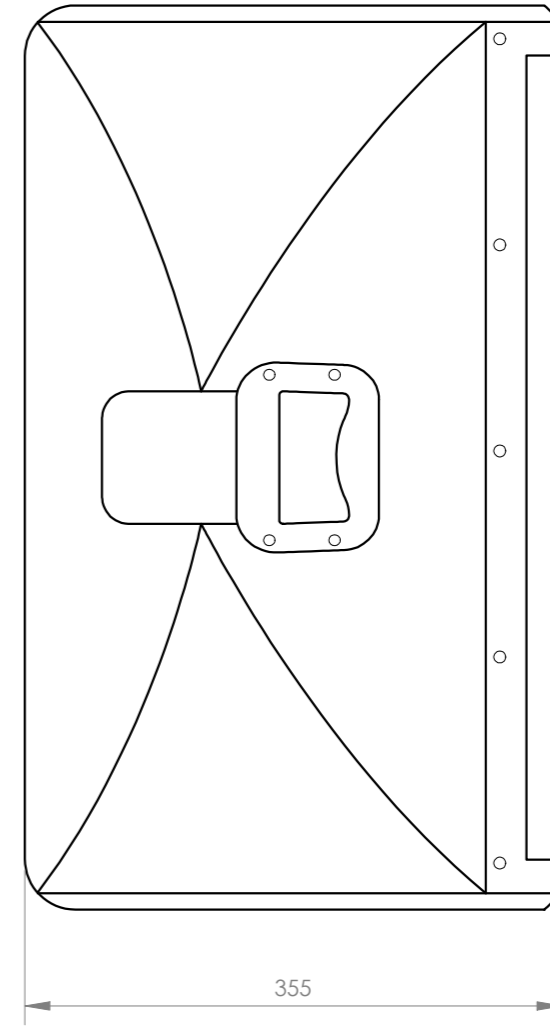
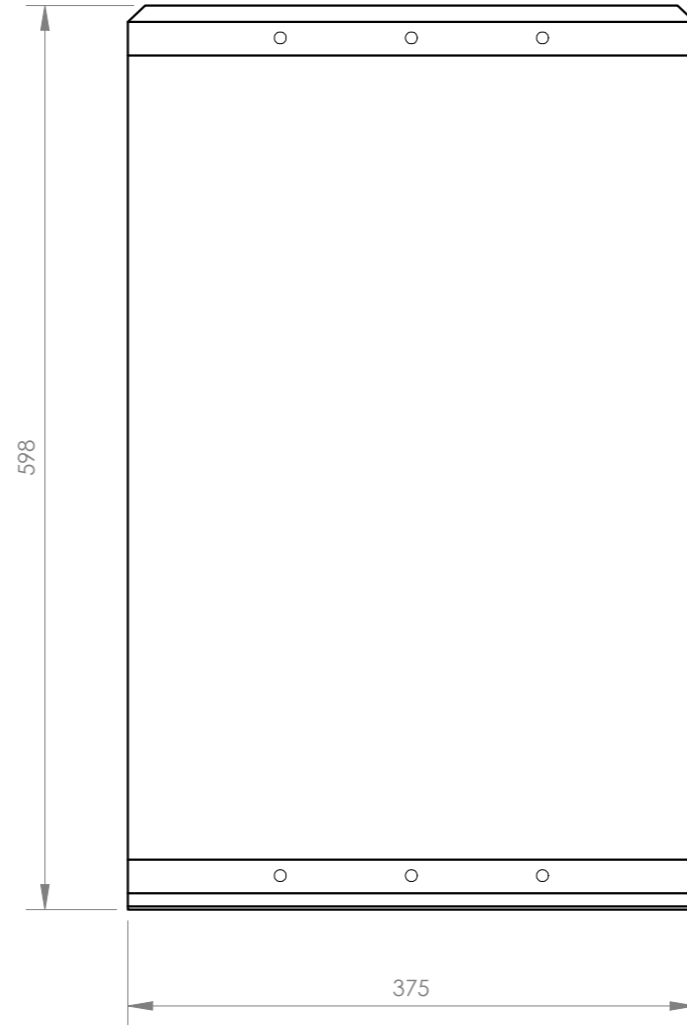
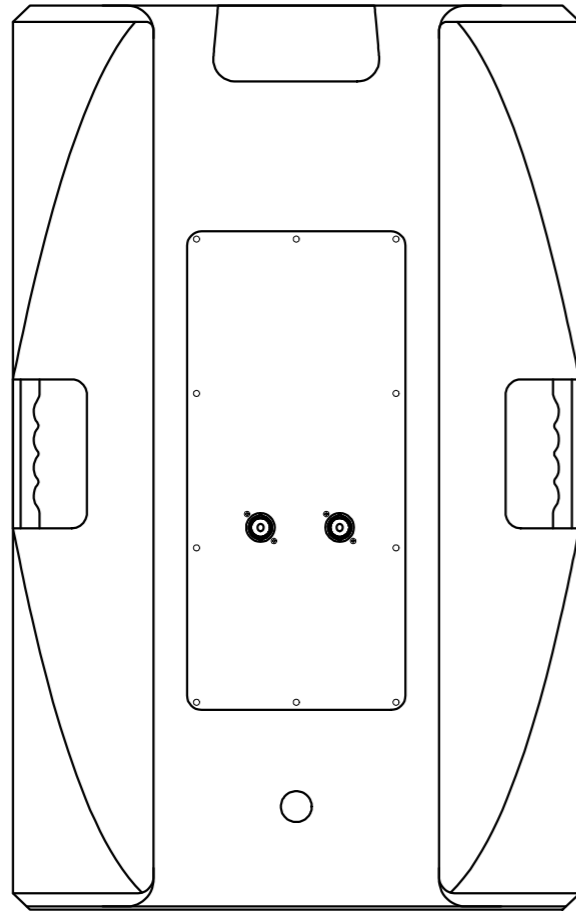

FONESTAR	Model	Description	Units	Scale
	FORCE-12	PASSIVE HIGH-POWER LOUDSPEAKER	mm	1:5