

# SL-400V

100 V LINE LOUDSPEAKER SELECTOR

INSTRUCTION MANUAL



**FONESTAR**

We take this opportunity to thank you for buying this product.

We recommend you read the instruction manual before switching on the machine and follow the instructions that are given. Keep the manual for future reference.

## SECURITY AND THE ENVIRONMENT

### ELECTRICAL SECURITY

Check that the current in the mains connection where the machine is to be installed corresponds to the power supply of the machine.

To avoid damaging the equipment, electrical shocks, fire or physical injury when you connect or disconnect the equipment from the power supply, pull the plug firmly out of the mains socket holding the plug, never the cable.

Always do this with dry hands.

Keep the power supply cable far from sources of heat. Do not put heavy objects on top of it or change it.

Clean dust and dirt off the power supply cable regularly.

Do not open the machine; you could get an electric shock.

### CAUTION

While installing the machine, make sure it is switched off and unplugged.

Do not open the machine. Touching the internal parts is dangerous and you could receive an electric shock.

The machine must not be splashed or dripped on. Never place recipients with liquid inside on the machine.

Do not place anything inside the machine.

### LOCATION

Place the equipment on a horizontal surface with enough space around it to allow ventilation.

Avoid direct sunlight, heat sources and excessive dust.

Do not place the machine near magnetic fields or static electricity.

Do not use surfaces which vibrate or receive impact.

Do not pile machines on top of one another.

### VENTILATION

Never block or cover the ventilation slits on the machine.

Do not expose it to direct sunlight or place it near sources of heat.

### PERIODS OF INACTIVITY

When the machine is not going to be used for a long period of time, disconnect it from the mains.

If you are using an adapter, take into account that it will continue using electricity even if the machine is switched off. If it is not going to be used for a long period of time, disconnect it from the mains.

### THE ENVIRONMENT

To save energy, switch the machine off when you are not going to use it for a long time. The machine could contain substances that are harmful to the environment or human health. To minimize the effect of these substances the machine must be correctly managed and recycled when you decide to dispose of it.

When you dispose of it remember: it cannot be thrown into a conventional rubbish bin.

If it contains or uses batteries, these must be disposed of separately.

The machine (without batteries) must be disposed of correctly. Put it in a container specially intended for the collection of electronic and electrical appliances, at the dump or hand it over to the dealer when you purchase similar equipment, so that the dealer can dispose of it correctly (at no added cost).

## SIGNIFICANCE OF THE SYMBOLS ON THE MACHINE\*



The symbol formed by the expression “Class 1 laser product” written in a rectangle indicates that visible or invisible laser radiation could be produced. Avoid direct exposure to the laser.



The symbol formed by a ray of lightening inside a triangle shows that the machine has connection terminals or a circuit with areas with a current which could cause an electric shock, even in normal working conditions.



The symbol formed by an exclamation mark in a triangle shows that the instruction manual must be referred to for information on how the machine works and its use.



The symbol formed by one square inside another square shows that the machine has double electrical insulation.



The European Community symbol shows that the machine complies with the current European Union legislation, as well as its transposition to local legislation.



The symbol of a rubbish bin crossed out and over a horizontal line shows that when the product is disposed of it must be done properly, placing it in a special selective electronic and electrical equipment container or through a dealer when purchasing a similar product, at no additional cost. It also shows that the machine was put on the market after 13th August 2005 (European Community Directive 2002/96/CE of Electrical and Electronic recycling, and its Spanish equivalent R.D.208/2005).

In accordance with what is set out in the aforementioned decree, FONESTAR is registered in the RAEE (Registro de Aparatos Eléctricos y Electrónicos) in a special section REI (Registro de establecimientos Industriales), with the entry number 001851.

The symbol RoHS (Restriction of Hazardous Substances) shows that the product has been designed and manufactured restricting the use of certain dangerous material (Directive 2009/95/CE on the restriction of certain dangerous substances in electrical and electronic appliances, and its transferal to the Spanish regulations, R.D. 208/2005).

\*It is possible that some of these symbols do not appear on the machine.

### EXEMPTION OF LIABILITY

The characteristics of the equipment and the content of the manual can change without forewarning. **FONESTAR, S.A.** does not assume responsibilities regarding the inappropriate use of the equipment or the information supplied in this instruction manual, and specifically disclaims any implied liability for marketability or fitness for any other use.

All rights reserved by **FONESTAR, S.A.**

## DESCRIPTION

- 4 line 100 V mono loudspeaker connector with independent volume control and A and B input selector.
- Attenuation with autotransformer.
- Power: 300 W maximum, 150 W RMS per channel.

## CONTROLS AND FUNCTIONS

### FRONT PANEL

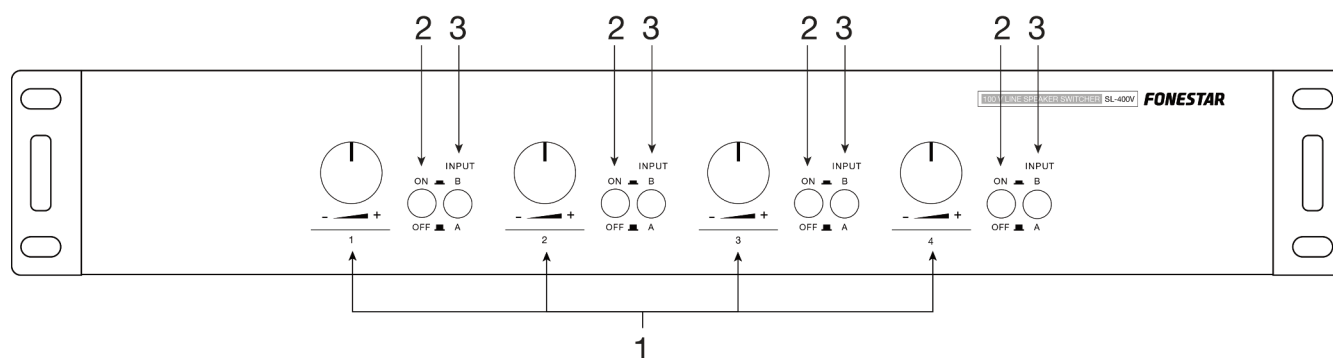

- 1.- **Outputs 1-4 volume control:** 12-position individual volume control for each loudspeaker line.
- 2.- **ON/OFF:** activates and deactivates each of the loudspeaker lines. If the button is pressed the selected line is activated, and if it is not pressed, the selected line is deactivated.
- 3.- **INPUT A-B:** allows selection of the amplifier input A or B for each of the loudspeaker lines.

### REAR PANEL

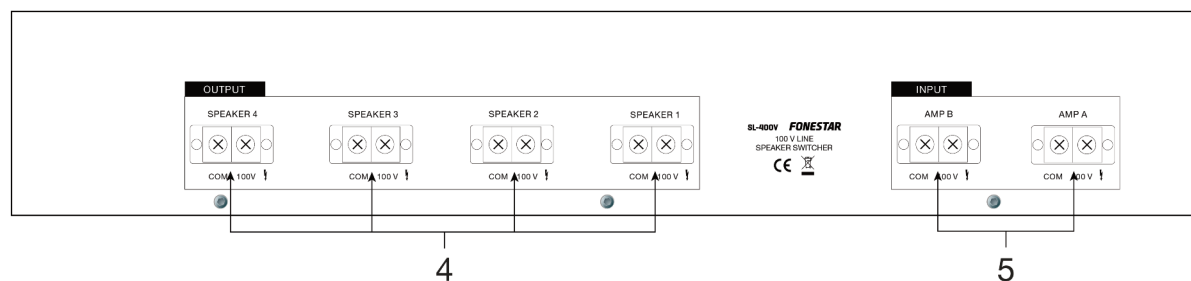

- 4.- **SPEAKER 1-4:** 100 V line loudspeaker output terminals.
- 5.- **AMP A-B:** 100 V line amplifier input terminals.

## CONNECTION

Make the connections with the amplifier and all the audio system components switched off and disconnected from the mains.

Connect the 100 V line amplifiers to the A and B inputs.

Connect the loudspeakers to the corresponding loudspeaker output in parallel. Additionally, you should take into account that the sum of the power of all the loudspeakers in each line must not exceed the power supplied by that line (150 W RMS).

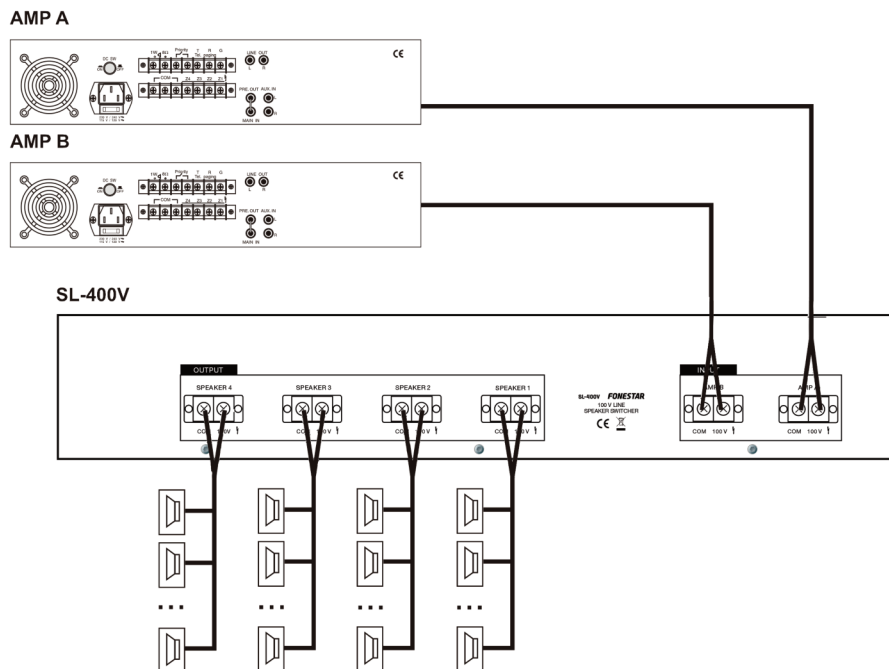

## TECHNICAL SPECIFICATIONS

	<b>SL-400V</b>
<b>CHARACTERISTICS</b>	4-line 100 V mono loudspeaker selector with independent volume control and A or B input selector. Attenuation with autotransformer. Each output can be individually activated/deactivated.
<b>POWER</b>	300 W maximum, 150 W RMS per channel
<b>INPUTS</b>	2 x 100 V line amplifiers
<b>OUTPUTS</b>	4 x 100 V loudspeaker lines
<b>CONTROLS</b>	On/off, A/B input selector and 12-position independent volume control, 42 dB attenuation
<b>DIMENSIONS</b>	432 x 76 x 190 mm depth. 1.7 U 19" rack
<b>ACCESSORIES</b>	19" rack mounts

## WARRANTY

This product has been tested and has passed the corresponding quality control prior to being put on the market. **FONESTAR** guarantees the suitability of the product for its specified use during a period of 2 years from the delivery date and commits itself to repair or substitute the goods as expressed in the Spanish law 'La Ley General para la Defensa de los Consumidores y Usuarios, Real Decreto Legislativo 1/2007 16 Noviembre.

The lack of conformity in the first six months after purchase, due to a manufacturing defect, will be rectified with no more than showing the proof of purchase. After six months **FONESTAR** reserves the right to demand proof of the product being sold with that problem.

This warranty does not include damage produced by: inappropriate use or negligence, accidents, worn out parts due to use, breakages, burns, spilt liquids or other substances, excessive humidity, battery deterioration and internal manipulation of the device, the software or its components by unauthorized persons, and in general any use that is unrelated to the nature and purpose of the product.

If any service is needed during the warranty period because of lack of conformity, please contact the business or distributor where the product was purchased in no more than 2 months after being conscious of the problem. It is only necessary to contact **FONESTAR** if it is impossible or imposes an undue burden for them to solve it.

To benefit from this warranty it is necessary to show the proof of purchase with the date clearly visible, with no corrections or crossing out.

This document adds information, and never decreases the consumers' rights, which in all cases are protected by the Spanish law 'La Ley General para la Defensa de los Consumidores y Usuarios, Real Decreto Legislativo 1/2007 16 Noviembre'.



® **FONESTAR** is a member of ECOEMBALAJES ESPAÑA, S.A. "ECOEMBES", with number 03497 and all our products carry the symbol, backed by our membership and subscription to the above mentioned organization with the recycling and subsequent management of our packaging.

FONESTAR, S.A. - NIF: A28780443 - Poligono Trascueto - 39600 - Revilla de Camargo, Cantabria (SPAIN)

[www.fonestar.com](http://www.fonestar.com)