

PUBLIC ADDRESS / LOUDSPEAKERS / SOUND PROJECTORS

PF-35T

UNIDIRECTIONAL SOUND PROJECTOR



- ✓ Great reach and sound quality.
- ✓ Prepared for outdoor use
- ✓ IP-66 protection

ESPECIALLY RECOMMENDED IN:



All sectors



+ Info:
<https://fonestar.com/PF-35T>

DESCRIPTION

Sound projector with diffuser and 100 V line transformer.

Wide range and sound quality with low dispersion.

Prepared for outdoor use thanks to its sealed ABS case, stainless steel screws and weatherproofed adjustable fixing mount protection.

Easy installation.

Perfect for background music and voice announcements in outdoor areas of shopping centres, car parks, bus stations, train stations, factories, etc.

TECHNICAL CHARACTERISTICS

FEATURES	Sound projector with diffuser and 100 V line transformer.
LOUDSPEAKERS	1 x 6" weatherproofed woofer 1 x 1" tweeter
RESPONSE	90-20,000 Hz
IMPEDANCE	50 W RMS@100 V (200 Ohm) 30 W RMS@100 V (330 Ohm) 15 W RMS@100 V (670 Ohm)
SENSITIVITY	99 dB at 1 W/1 m
DISPERSION	90° H x 80° V
PROTECTION	IP-66
MATERIAL	ABS. Hermetic casing Weather-resistant mount Stainless steel screws
COLOUR	Grey (RAL 7035)



+ Info:
<https://fonestar.com/PF-35T>

DIMENSIONS	356 x 256 x 292 mm depth, without mount.
WEIGHT	3.5 kg
ACCESSORIES	Adjustable fixing mount



+ Info:
<https://fonestar.com/PF-35T>

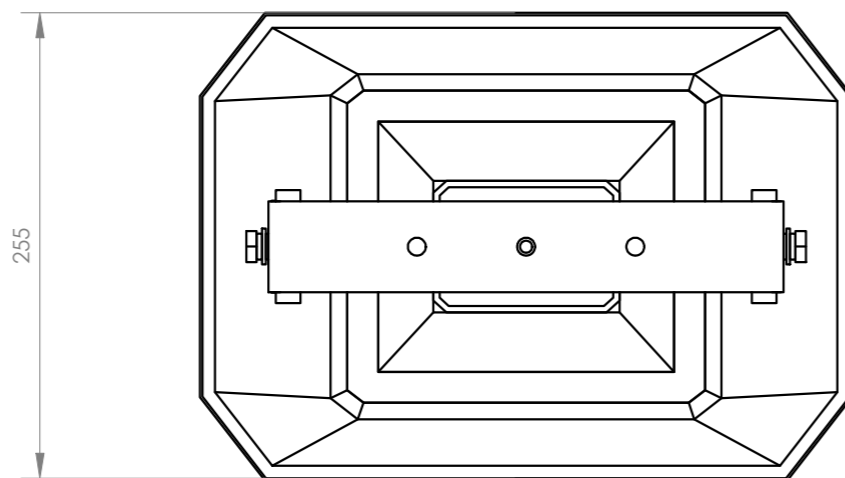
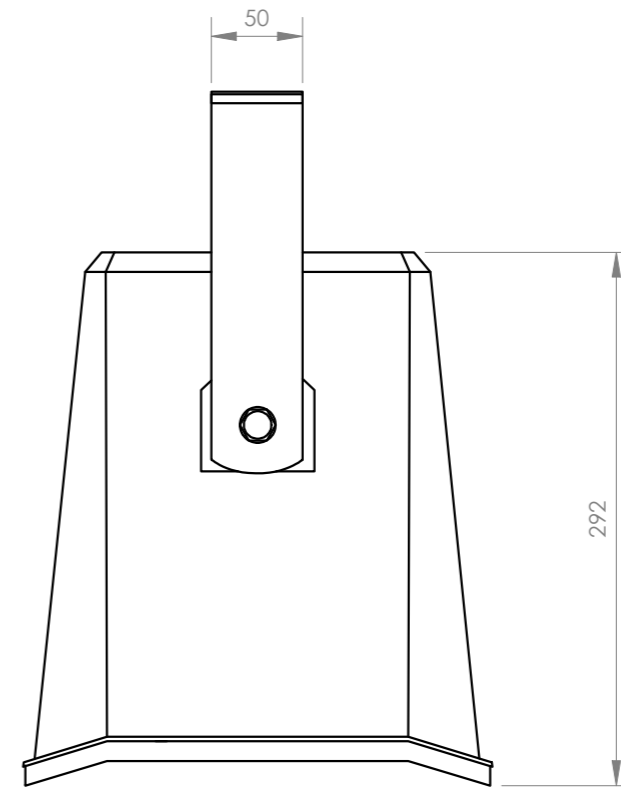
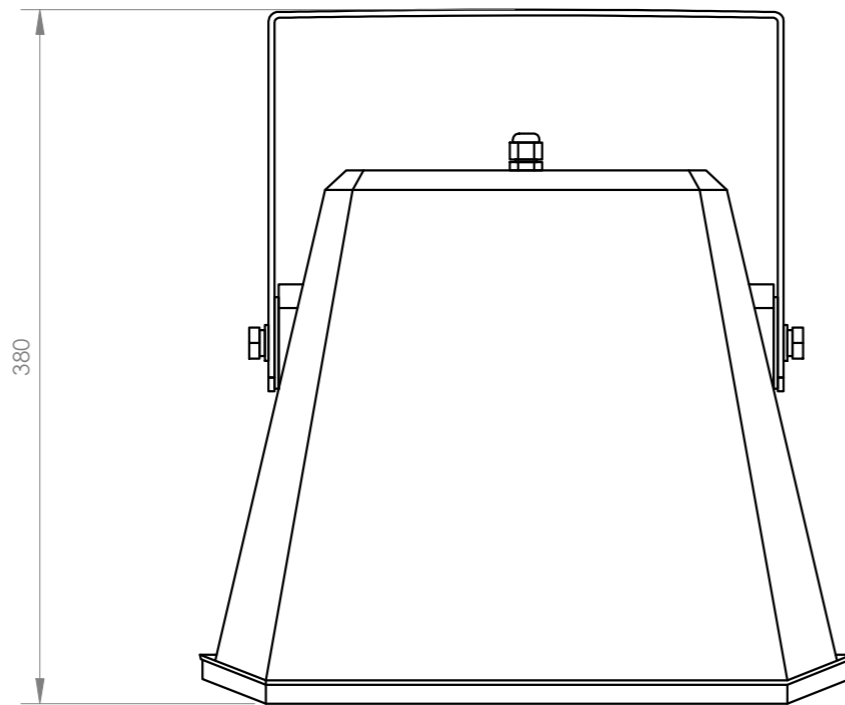
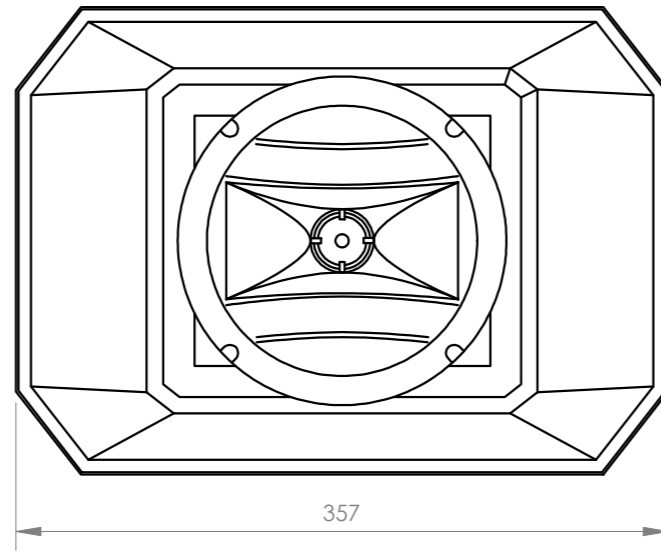

FONESTAR	Model	Description	Units	Scale
	PF-35T	UNIDIRECTIONAL SOUND PROJECTOR	mm	1:4

↑ → SPL vs Frequency

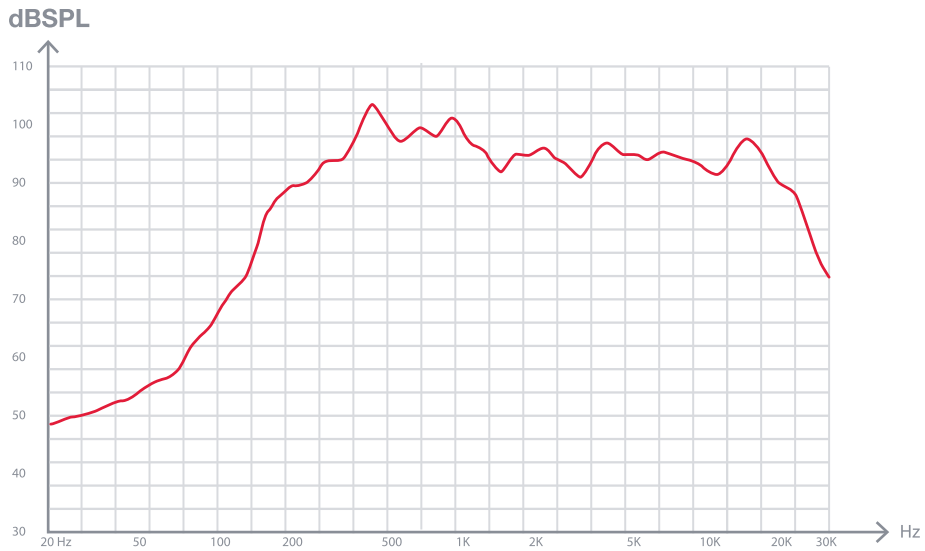

↑ → SPL vs Angle HORIZONTAL

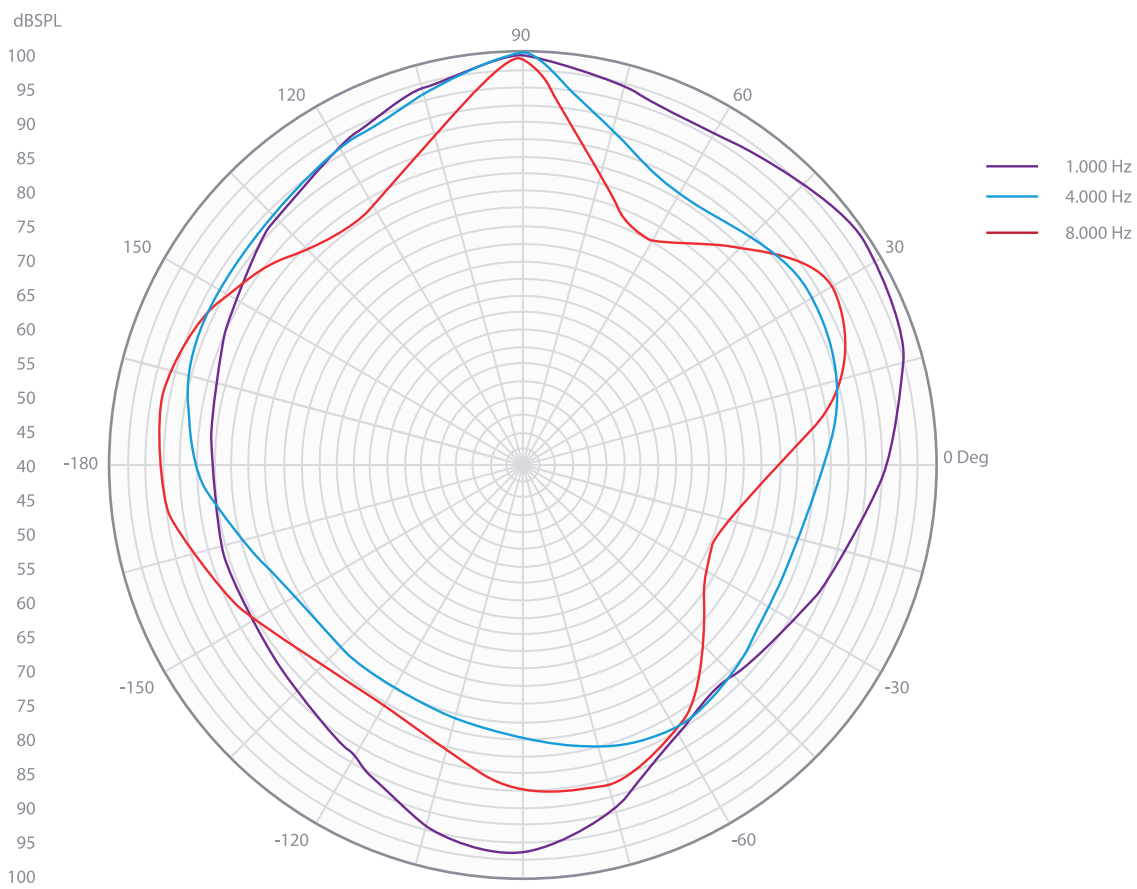

+ Info
<https://fonestar.com/PF-35T>

SPL vs Angle VERTICAL

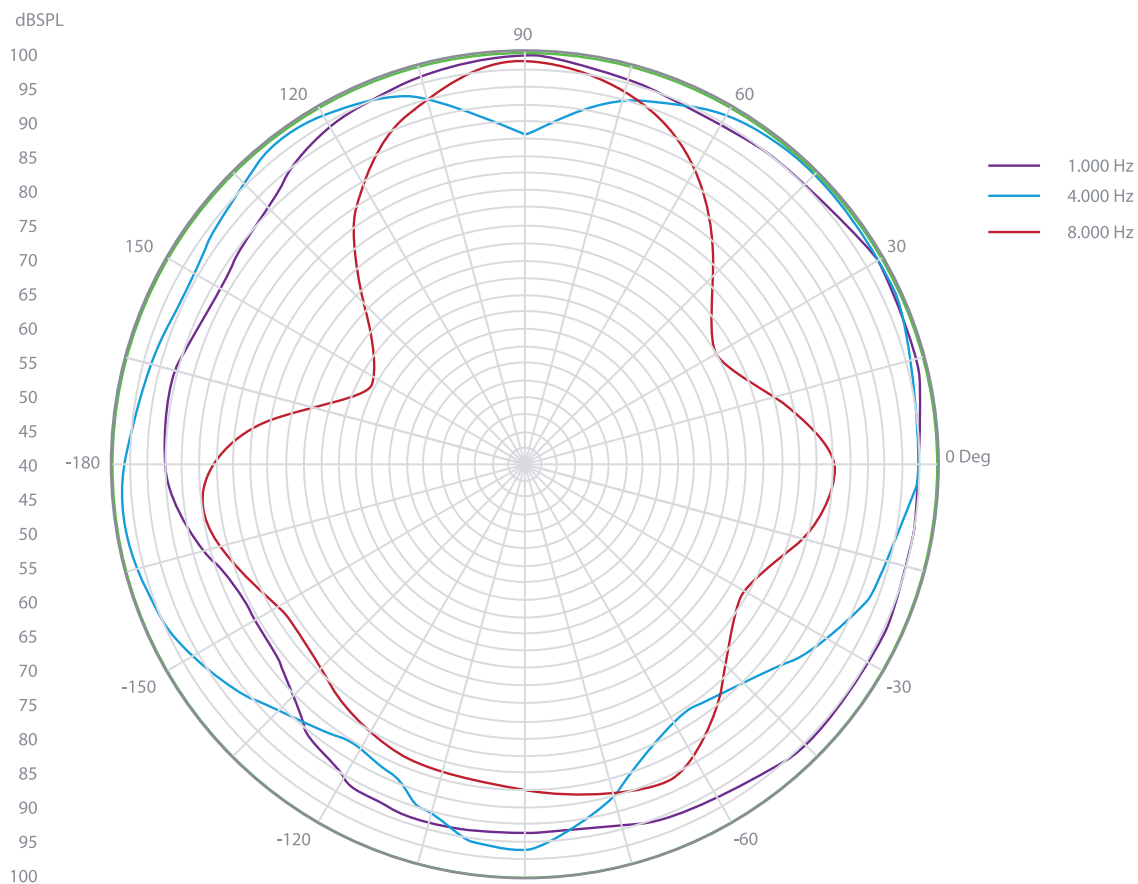

+ Info
<https://fonestar.com/PF-35T>