

PUBLIC ADDRESS / ATTENUATORS / ATTENUATOR ACCESSORIES

DOT-01N

PANEL FOR DOT SERIES DIMMERS

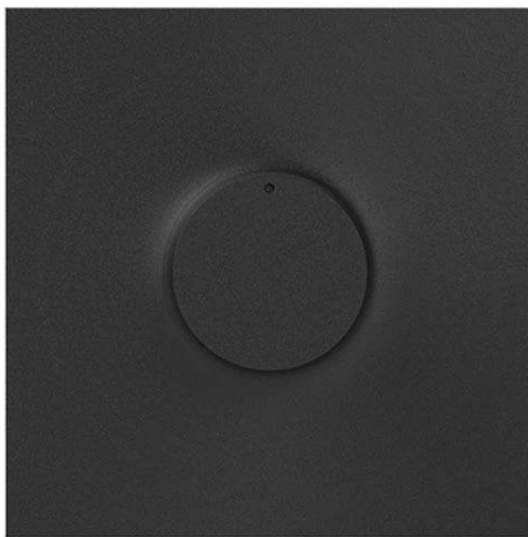

- ✓ Ergonomic design
- ✓ Minimalist aesthetic
- ✓ Easily interchangeable with white

ESPECIALLY RECOMMENDED IN:



All sectors



+ Info:
<https://fonestar.com/DOT-01N>

DESCRIPTION

Panel for DOT series attenuators.

Minimalist aesthetics, with FONESTAR's own design, taking into account the needs of the market to make them go unnoticed in any installation, whether domestic or professional.

For installations requiring black attenuators, easily interchangeable with white.

Public address and voice evacuation systems, large and small shops, shopping centres, hotels, cafés, amusement arcades, domestic use, etc.

TECHNICAL CHARACTERISTICS

FEATURES	DOT series attenuator panel.
COLOUR	Black
DIMENSIONS	83 x 83 x 13 mm depth



+ Info:
<https://fonestar.com/DOT-01N>

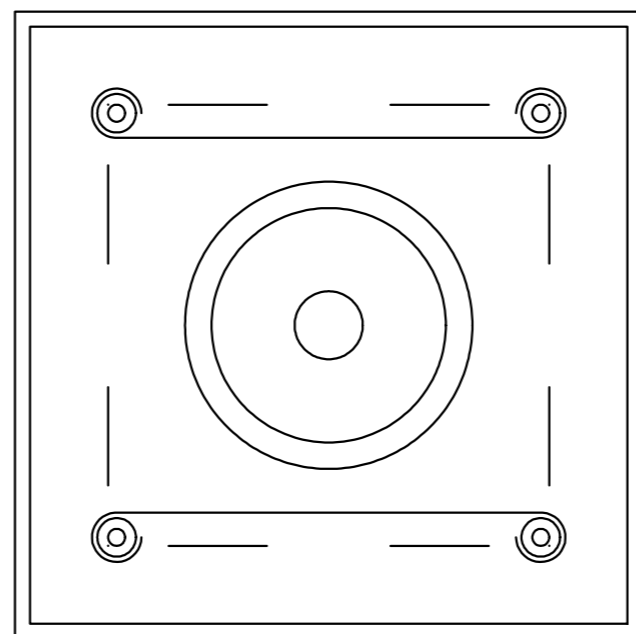
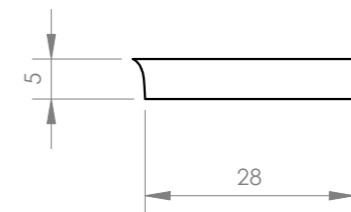
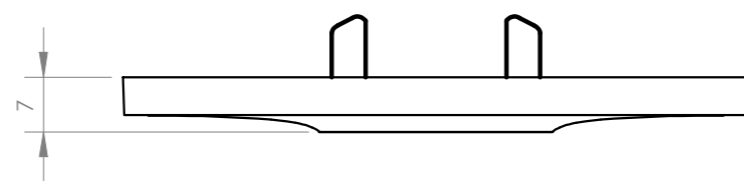
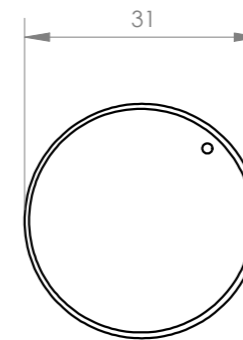
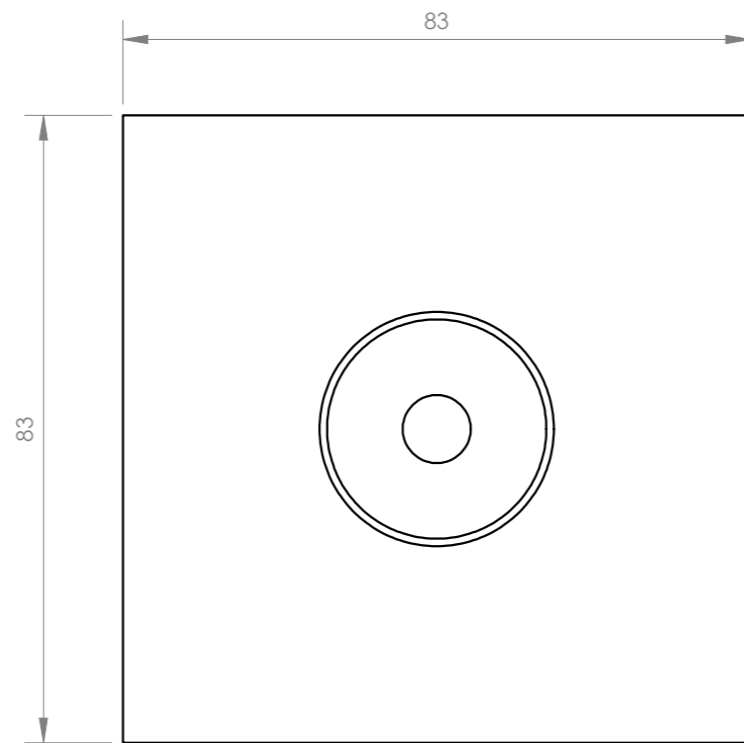

FONESTAR	Model	Description	Units	Scale
	DOT-01N	PANEL FOR DOT SERIES DIMMERS	mm	1:1