

*Studiomaster*  

---

by RSD

**AXX**

**1500**

**2500**

**3500**

**Professional Power Amplifiers**

**USER GUIDE**

**Contents****Instructions**

Unpacking	1
Safety Instructions	1
Front panel controls and features	2
Rear panel controls and features	3 - 5
Operation	6
Ventilation	6
Protect LEDs	6
Cables	7
Rack Mounting	7
Trouble Shooting	7
Service Information	8

**Technical Information**

Technical Specification	9 - 10
Glossary of Terms	11

**Set-up Diagrams**

Mono Mix	12
Stereo Mix	12
Mono Bi-amp	13
Stereo Bi-amp	13
2-way Monitor Mix	14
Stereo Bi-amp with Mono sub bass	14
2-way stereo with additional amplifiers	15

<b>Notes</b>	<b>16</b>
--------------	-----------

Congratulations on your purchase of a Studiomaster AX Series power amplifier. Like all Studiomaster products, it has been designed to meet the highest standards of performance, safety and reliability. We are confident that this amplifier will fully meet your needs for many years to come. Please read this guide carefully and keep it safe in case you need to refer to it in the future.

## Unpacking

Remove your AX amplifier from its packing. Check that the carton includes an AC power cord/mains lead and a warranty card. It is important to retain the carton and all packing material in the event that the unit needs to be returned to your dealer for service or repair. Please complete and return your warranty card. Returning the completed warranty card does not diminish your statutory rights in any way.

## Safety instructions

1. Make sure you have the correct product for your local supply Voltage. This will be marked on the rear panel of the amplifier.
2. Only use the A.C. power cord/mains lead supplied with the product. If it becomes damaged in any way it should be replaced.
3. Never operate without, or remove, the safety ground (earth) from the A.C. power cord/mains lead.
4. Do not attempt to remove screws or panels. There are no user serviceable parts inside.
5. Do not operate the unit next to heat sources such as electric fires, central heating etc.  
Note : Exposure to strong sunlight (eg outdoors) could cause the amplifier to over heat.
6. The unit should not be operated or stored near rain or moisture.
7. This equipment must not be exposed to dripping or splashing and no objects filled with liquids should be placed on top of it.
8. Always ensure that both front and rear ventilation holes are clear of obstructions.
9. Write the serial number in the box provided below for future reference.

10. If the unit gets damaged or appears to have developed a fault refer to the Service Information section for details.

**WARNING: THIS APPARATUS MUST BE EARTHED (GROUNDED)**

## Front panel controls and features

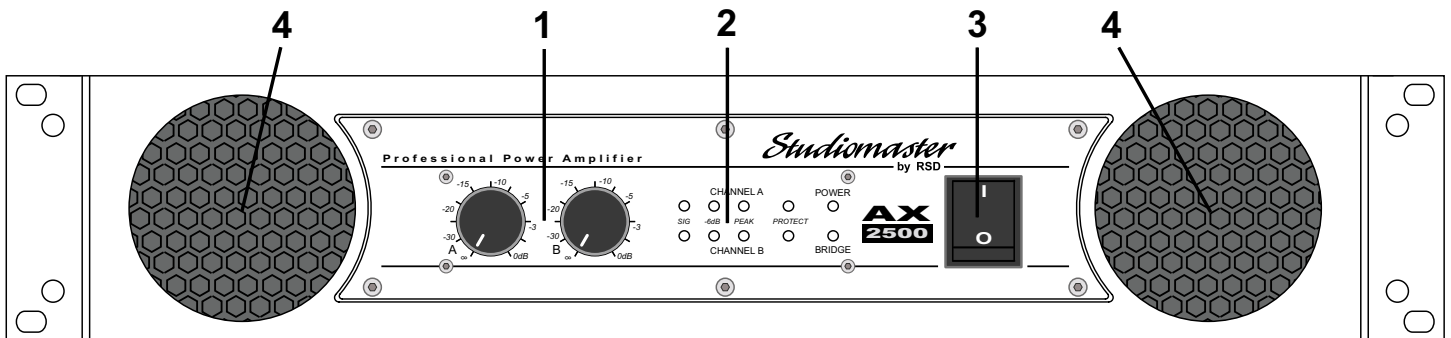

1. **LEVEL** controls adjust signal levels for channels A and B.
2. Status LEDs indicate the following:
  - a **SIG** indicates a signal is present and sound should be heard from the speakers.
  - b **-6** shows a strong signal is present.
  - c **PEAK** shows maximum output power has been reached. Increasing the level control or input signal will not increase the output power.
  - d **PROTECT** illuminates when the amplifier is muted at switch on. After a couple of seconds they will turn off and the speakers are connected for normal operation. If at any stage, they stay illuminated, a fault has occurred. See section under PROTECT LEDs for more information.
  - e **POWER** shows the amplifier is switched on.
  - f **BRIDGE** indicates the amplifier is in BRIDGE mode.
3. **POWER** switch.
4. Fan ventilation holes. Do not obstruct.

## Rear panel controls and features

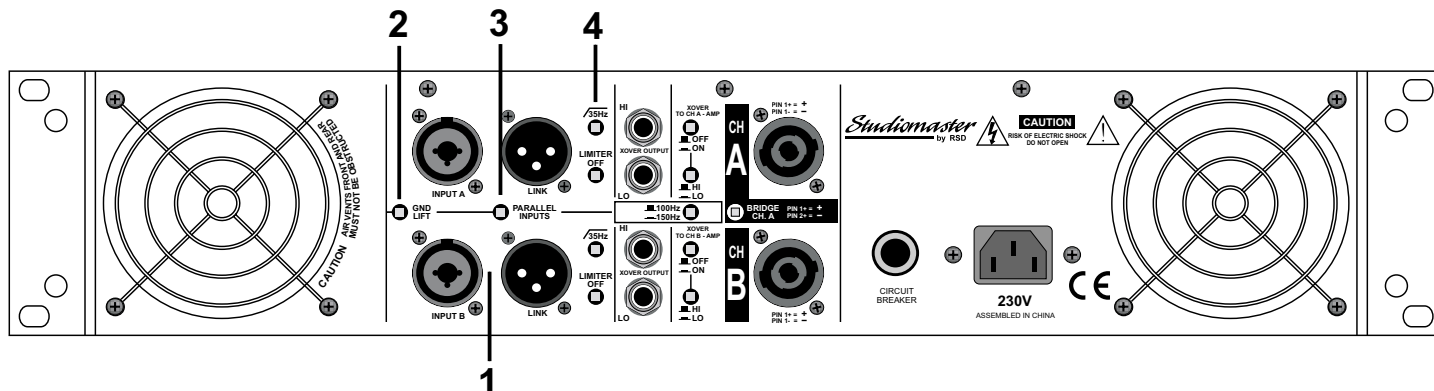

1. There are two **INPUT CONNECTORS** per channel. One is a combination 3 pin XLR and 3 pole (TRS) ¼" jack socket, the other a male XLR for linking to other amplifiers. Both balanced and unbalanced signals can be used to drive the amplifier.

**XLR connector wiring**

Balanced Operation

PIN 1 Ground

PIN 2 +Ve/in-phase signal

PIN 3 -Ve/out-phase signal

Unbalanced operation

PIN 1 Ground

PIN 2 +Ve/in-phase signal

PIN 3 Link to ground (pin1)

**Jack connector wiring**

Balanced Operation

3 pole/TRS/stereo ¼ " jack

TIP +Ve/in-phase signal

RING -Ve/out-phase signal

SLEEVE Ground

Unbalanced operation

2 pole/TS/mono ¼ " jack

TIP +Ve/in-phase signal

SLEEVE Ground

2. Input **GND LIFT** (ground lift) switch removes the ground connection to all input connectors. This can solve hum loop problems when connecting equipment with different A.C. supplies. Under no circumstances should the electrical safety ground (earth) from the A.C. supply be disconnected.
3. **PARALLEL INPUTS** links Channel A input to Channel B. A single input signal will now supply both channels. The volume levels of each channel can still be adjusted individually.
4. **35Hz high pass filter** reduces the level of very low frequency signals reaching the speakers, improving bass clarity and power handling. It is recommended that this filter is always used for live P.A/Sound re-inforcement. Ported / Vented / 'bass reflex' speaker cabinets can be damaged if driven with high power low frequency. For Studio monitoring where a totally flat response is required, deselect the High Pass Filter. The filter has an 18dB / octave cut-off slope.

## Rear panel controls and features

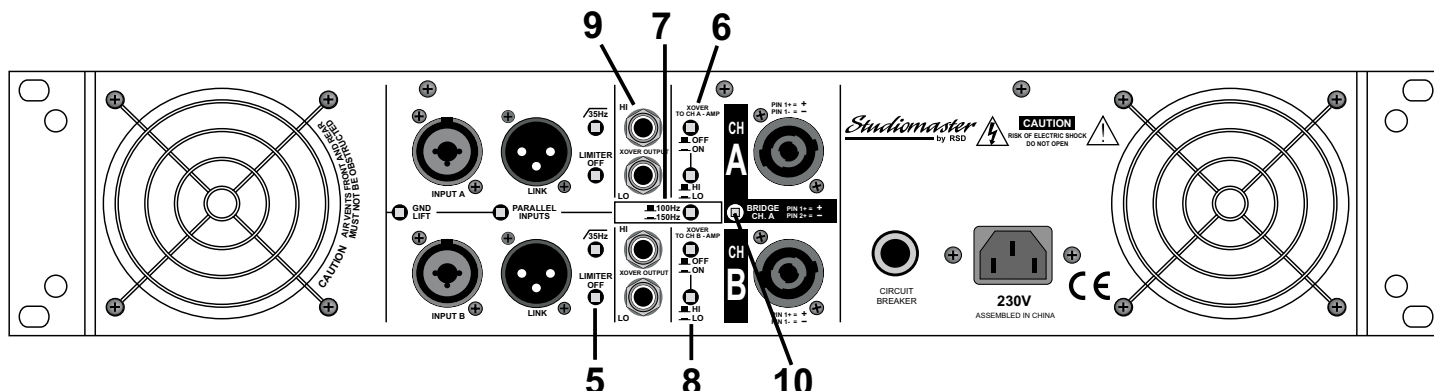

5. **LIMITER OFF** disables the clip limiter circuit. At maximum power output, the limiter virtually prevents amplifier clipping, minimising audible distortion. It should only be turned off in specific applications, as serious speaker damage can occur if the amplifier is allowed to clip regularly.
6. **X-OVER** turns on the internal two way crossover circuit. The crossover splits the audio band into high frequencies, suitable for mid/high speakers and low frequencies suitable for bass speakers. If the crossover function is not required this switch should remain off (out position).
7. The **frequency** switch selects the crossover frequency between 150Hz and 100Hz. For most systems 150Hz is recommended although some, typically when using 18" subs, will work better with 100Hz. The internal crossover has a '3rd order' response.
8. **HI LO** selects which signal from the crossover the amplifier receives. When HI (out position) is selected only frequencies above 100 or 150Hz feed the amplifier. When LO (in position) is selected only frequencies below 100 or 150Hz feed the amplifier.
9. **XOVER OUTPUT** sockets allow the high or low frequencies from the crossover circuit to feed additional amplifiers. See examples in the Set Ups section.
10. **BRIDGE** mode combines the output power of both amplifier channels into one load. This is useful when driving a single, high powered speaker. Only channel A output socket connects to the speaker but has to be wired in a different way. See the section below regarding speaker wiring. In this mode only Channel A input and level control are used.

Rear panel controls and features

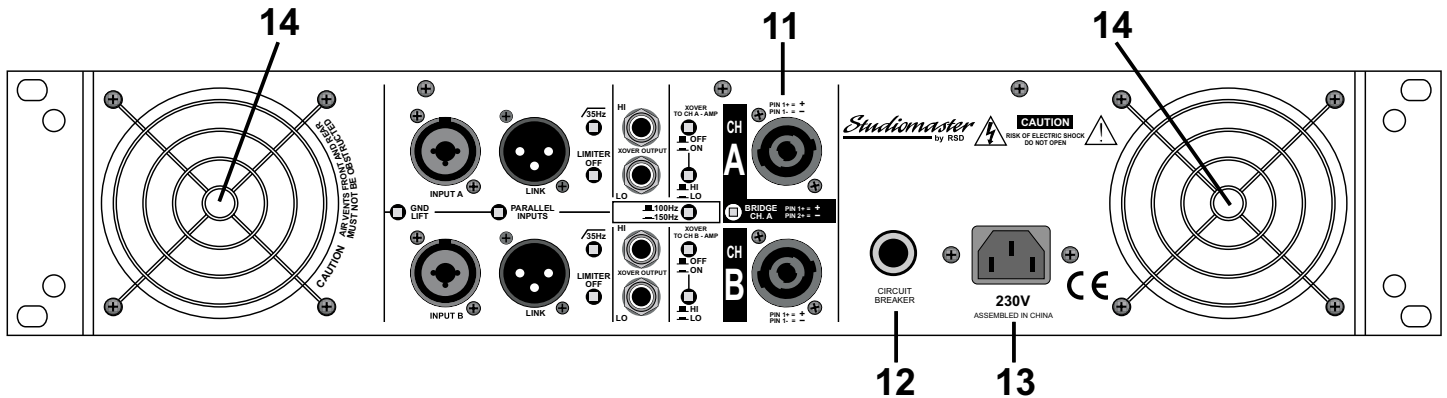

11. **Speaker Wiring.** Each channel uses SPEAKON NL4 connectors. Using cable as specified (See CABLES) speaker connections are as follows:-

Each channel connected individually to a speaker:

PIN 1+ Positive (+)	PIN 2+ Not used
PIN 1- Negative (-)	PIN 2- Not used

Two Speakers connected to both channels in a single 4 core cable:

Use only Channel A connector wired:

Channel A PIN 1+ Positive (+)	Channel B PIN 2+ Positive (+)
Channel A PIN 1- Negative (-)	Channel B PIN 2- Negative (-)

Bridged operation:

Use only Channel A connector wired:

PIN 1+ Positive (+)	PIN 2+ Negative (-)
PIN 1- Not used	PIN 2- Not used

Always ensure speaker cables are wired the same way. When any cable has the pin wiring reversed, some speakers will be out of phase, usually resulting in a loss of volume or bass.

12. **Circuit Breaker** will only activate if the amplifier has developed a fault or been driven too hard into very low speaker impedances. The button on the circuit breaker will protrude approximately 6mm when tripped. Check speaker wiring and load before re-setting. To reset turn off the amplifier power switch and push in the reset button. If the breaker trips again, the amplifier could have developed a fault. If this happens refer to the Service Information section.
13. **A.C. power inlet.**
14. Fan ventilation holes. Do not obstruct.

## Operation

Decide the required mode for the amplifier and select the appropriate rear panel switches. The set up diagrams later in this guide will help.

Always ensure that all signal and power connections to the amplifier are properly made before switching on. It is recommended to turn the level controls to minimum initially as well.

Any amplifier(s) in a system should always be switched on LAST and switched off FIRST to prevent damaging thumps, originating from other equipment.

### Hints and tips

1. Make sure that the speakers being used have the correct power rating for the amplifier. This will help avoid possible damage to the speakers.
2. The optimal speaker load impedance for power delivery and long term operation is 4 ohms per channel; 8 ohms in bridged mode.  
The amplifier will operate into 2 ohm loads; 4 ohms bridged, although continuous flashing of the PEAK LED should be avoided to prevent thermal protection shutting down the amplifier.
3. Always use the LIMITER (rear panel switch in the out position) as it helps prevent distortion on large signal peaks.
4. Use the 35Hz filter (rear panel switch 'in' position) as it will improve the bass power handling and clarity of the system. This is especially important with vented / ported / 'bass reflex' cabinets.
5. When used with a pro-audio mixer, adjust the level controls to a position compatible with the mixer metering. A suggested starting position for the level controls is '-10'.

## Ventilation

It is essential that air can circulate freely around the amplifier to provide adequate cooling. The fans take air in from the rear of the amplifier and exhaust through the front panel. Both the front and rear ventilation holes must not be obstructed.

When the amplifier is rack mounted, care must be taken to ensure that the rack is open at the front and rear to allow sufficient air flow.

In some installations, racks are fitted with covers for security reasons. If these restrict the air flow in any way they must be removed while the amplifier is in operation.

Where multiple amplifiers are installed in a rack, additional forced ventilation or a source of fresh cooling air may be required.

## Protect LEDs

Operate independently and show that the speaker outputs have been muted resulting in no sound. They illuminate under the following conditions:

1. When the amplifier is turned on. After a couple of seconds the LEDs will turn off showing normal operation.
2. If the amplifier has reached an over temperature condition the volume of one or both channels will rapidly reduce resulting in little or no sound. Once the fans cool down the heatsinks, normal operation will resume. However, if the transformer has overheated then it can take a few hours to cool.
3. If a fault has occurred on one or both channels the relevant PROTECT LED(s) will stay illuminated and there will be no output. The amplifier should be returned to an authorised Studiomaster service centre in the original packing, to prevent shipping damage. See Service Information.



## Cables

Speaker cables should be as short and as heavy gauge as possible to prevent unwanted power loss caused by high resistance, which can result in loss of both signal level and quality. Heavy duty, twin core A.C. power cable is generally suitable.

Cable with a conductor size of 1.5mm<sup>2</sup> / 16AWG, 2.5mm<sup>2</sup> / 14AWG or 4.0mm<sup>2</sup> / 12AWG is recommended. Note the losses caused by using thinner cable:

Cable length	Wire size	Loss @ 8 ohms	Loss @ 4 ohms	Loss @ 2 ohms
5 metres	1.0mm <sup>2</sup> /17AWG	2.15%	4.1%	7.75%
10 metres	1.0mm <sup>2</sup> /17AWG	4.12%	7.75%	14%

## Rack Mounting

The AX series amplifiers are designed to be fitted into a standard 19" rack. They each occupy 2 Units (2U) of rack space. If the amplifier is to be used in a mobile application, a good quality, flight cased amp rack is essential if damage is to be prevented. We recommend the use of 6mm rack screws with plastic or nylon washers underneath the screw heads to avoid damaging the front panel.

Always use both the front and **rear** mounting holes, especially for mobile and touring applications.

## Trouble Shooting

### No power on LED...

1. Check A.C. power cord/mains lead is connected to the wall supply and switched on.
2. Check A.C. power cord/mains lead is fully pushed into the amplifier socket.
3. Check that the amplifier is switched on.
4. UK only - Check fuse in the 'mains' plug.
5. Check A.C. supply house breaker / fuse.

### No sound...

1. Check that the signal source (from mixer, CD player etc.) is working.
2. Check that the LEVEL control(s) are not in the minimum (anti clockwise) position.
3. Check that the speakers are connected correctly.

### Distorted sound and PEAK LED(s) illuminated...

1. Possible short circuit on speaker cable or cabinet. Change speaker cable and check cabinet.
2. If only on channel A, check a 4 core speaker cable is **not** being used with a speaker that links PIN1+ to PIN2+ of the Speakon connector.

### One or Both Amplifier channels stop working briefly...

(one or both Protect LEDs illuminate briefly)

1. Check the ventilation holes both front and rear for good air flow.
2. Check that the speaker load on each channel is not less than 2 ohms.
3. Check that the amplifier is not being over driven - red peak LEDs should not be illuminated 'continuously'.

### Amplifier stops working and one or more PROTECT LEDs are illuminated...

1. The amplifier is in an over temperature or fault condition. See PROTECT LED section for more information.

## Service Information

If you have a problem with your Studiomaster product or think it has developed a fault you should first carefully check the Trouble Shooting section in this guide. If this does not solve the problem or if the product is physically damaged, contact your local dealer or distributor for service details.

Should it be recommended you return the product to your nearest Studiomaster Service Centre you must first contact them.

You will be asked for the product type and serial number. You will then be given a Returns Authorisation (RA) number.

Pack the unit in its original carton to protect it from shipping damage.

You must have the Returns Authorisation number clearly marked on the outside of the carton or we may refuse the delivery. Studiomaster cannot be held responsible for damage resulting from the equipment being packed incorrectly.

Label the equipment clearly with your name and address and include a clear description of the fault. The more information you supply helps the service engineer, minimising repair cost when out of warranty.

Please write your Serial number here for future reference....

### Technical Specification

	AX1500	AX2500	AX3500
<b>Power Output in watts per channel</b> <i>At onset of Clipping</i> Both Channels 8 ohms	270	450	710
Both Channels 4 ohms	450	750	1100
Both Channels 2 ohms	575	990	1450
Bridged 8 ohms	900	1500	2200
Bridged 4 ohms	1150	1980	2900
<b>Input Sensitivity</b> Ref: Rated Power 4 ohms	0dBu 0.775V	0dBu 0.775V	0dBu 0.775V
<b>Distortion (THD)</b> 1kHz @ rated power (1 channel driven)	0.01%	0.01%	0.02%
<b>Frequency Response</b> 20Hz - 20kHz	+0/-0.5dB	+0/-0.5dB	+0/-0.5dB
<b>Signal to Noise Ratio</b> (unweighted) Ref: Rated Power 4 ohms	100dB	100dB	100dB
<b>Crosstalk</b> @ 1kHz	80dB	80dB	80dB
<b>Damping Factor</b> Ref : 1kHz 8 ohms	200	200	200

### Crossover

Selectable 100 / 150Hz. 3rd order filter

**Technical Specification**

	AX1500	AX2500	AX3500
<b>Input Filter</b> 3rd order (18dB / octave) -3dB @	35Hz	35Hz	35Hz
<b>Input Impedance</b>	10k Unbal 20k Bal	10k Unbal 20k Bal	10k Unbal 20k Bal
<b>Voltage Gain</b>	35dB	37dB	39dB

**Cooling** Continuously variable speed Twin Fans, back to front airflow.

**Amplifier Protection** Full short circuit, open circuit, thermal, ultrasonic and RF protection. All units are stable into mismatched or reactive loads.

**Load Protection** Power up/down muting.

<b>Output Circuit type</b>	AB	H (2)	H (3)
	AB : Class AB complementary linear output	H(2) : Class AB complementary linear output with Class H 2-step high efficiency circuit	H(3) : Class AB complementary linear output with Class H 3-step high efficiency circuit

**Dimensions**  
19" (48.3cm) width  
2U 3.5" (8.9cm) height  
15.5" (39.4cm) depth (rack mounting to rear rack ears)

<b>Weight</b>	Shipping	20.2kg (44.4lbs)	23.6kg (51.9lbs)	26kg (57.2lbs)
	Net	16kg (35.2lbs)	19.4kg (42.7lbs)	21.8kg (48lbs)

**Power Requirements**  
230V Model : 220-240V AC 50/60Hz  
120V Model : 110-127V AC 50/60Hz

<b>Power Consumption</b> @230V AC 1/3 power pink noise (double the current rating for 120V models)	4.6A	7A	8.2A
--	------	----	------

## Glossary of Technical Terms

<b>AC or a.c.</b>	Alternating current.		
<b>AC POWER SUPPLY</b>	Local electrical supply		
<b>BALANCED</b>	Balanced 3 connection circuitry is widely used in audio equipment from cheap dynamic microphones to top quality studio devices. The balanced system is used as it cancels outside interference in the connecting cables resulting in a cleaner signal		
<b>BANDWIDTH</b>	The bandwidth is the range of frequencies that will pass through a piece of equipment.		
<b>BRIDGE / BRIDGED</b>	In bridged mode both channels of the amplifier are combined to provide the total power of the amplifier into a single load.		
<b>COLD</b>	The negative phase of a signal. Usually the black wire in a balanced cable. For an unbalanced signal the SCREEN is used for the COLD connection.		
<b>DECIBEL (dB)</b>	A logarithmic method of measurement for acoustics and electronics. One decibel (1/10th of a Bel) is the 'standard' change in loudness perceptible by the human ear, although 'trained ears' can detect smaller changes. 0dB (acoustic) is the threshold of human hearing at mid range frequencies.		
<b>dBa</b>	The most commonly used unit for measuring sound pressure levels. The 'A weighting' takes account of the ear's varying sensitivity to different frequencies, which is most pronounced at low volumes.		
<b>dBu</b>	A standard reference voltage = 0.775 V rms. Derived from the earlier dBm which was used to measure the power in 600ohm circuits.		
<b>dBV</b>	A standard reference voltage = 1V rms.		
<b>F.O.H.</b>	Front of House. The speaker system which is used to project the sound from the stage to the audience. It is also used to describe the position, in front of the stage, where the main mixing console is situated.		
<b>FOLDBACK</b>	Sound which is sent from the main mixing position back to the stage so the performers can hear it. Often, with a large sound system an entirely separate foldback (or monitor) system with a dedicated console is located on one side of the stage so the performers can communicate easily with the operator.		
<b>GROUND</b>	Earth		
<b>HERTZ (Hz)</b>	A measurement of frequency. 1Hz = 1 cycle per second.		
<b>HIGH (or TOP)</b>	The treble or high frequency content of a sound or the speakers (often compression drivers attached to horns or flares) used to reproduce it.		
<b>HOT</b>	The positive phase of a signal. Usually the red wire in a screened cable.		
		<b>IMPEDANCE</b>	Similar to resistance, except that impedance also reflects the effect of any inductance or capacitance in the circuit.
		<b>KILOHERTZ (kHz)</b>	A measurement of frequency. 1000 Hertz = 1kHz (1000 cycles per second).
		<b>LEVEL</b>	The size of a signal, at any given point, in an audio system.
		<b>LINE LEVEL</b>	A signal level higher than microphone level used to interconnect equipment. A typical level of semi pro equipment is -10dBV while pro equipment is usually +4dBu and often balanced. Typical line levels can be from 100mV to 4V (-15 to +15dBu).
		<b>MONO</b>	Single channel sound reproduction (short for monaural).
		<b>MONITOR</b>	The speakers used by the performers or operator to hear signals in a recording studio or on-stage. Also used in live sound as an alternative name for FOLDBACK.
		<b>NOISE</b>	Any sound you didn't want (hiss, hum etc).
		<b>OHM</b>	A unit of electrical resistance. 1000 Ohms = 1kOhm (or 1000W = 1kW)
		<b>RESISTANCE</b>	A measure of the ratio of Voltage and Current in a circuit or component. Resistance (Ohms) = Voltage/Current.
		<b>RMS</b>	Root Mean Square. The method normally used to measure AC Voltages.
		<b>SCREEN</b>	The interference suppressing outer conductor in mic and line cables.
		<b>SEND</b>	The connectors or controls used to send a signal, connected externally to a mixing console.
		<b>SIGNAL TO NOISE</b>	The ratio used to describe the relationship between the level of a signal and the background noise that accompanies it.
		<b>SPEAKON™</b>	A high quality connector designed for use with high power amplifiers and loudspeakers.
		<b>SPL</b>	Sound Pressure Level.
		<b>STEREO</b>	Two channel sound reproduction where the two signals are sent to separate left and right speaker systems.
		<b>TRS</b>	Tip, Ring, Sleeve. 1/4" three pole jack plug. Often referred to as a stereo jack plug (phone jack in USA). Used for balanced line signals, insert (send /return) points and some stereo headphones.
		<b>TS</b>	Tip, Sleeve. 1/4" two pole jack plug. Often referred to as a mono jack (phone jack in USA). Used for unbalanced signals.
		<b>UNBALANCED</b>	Two wire connection using one signal and one screen conductor.
		<b>XLR</b>	An industry standard connector used for audio signals (usually 3 pin). They are used for low level signals (like microphones) and line level signals (as on the inputs of AX series amplifiers).



### 3 Mono Bi-amp

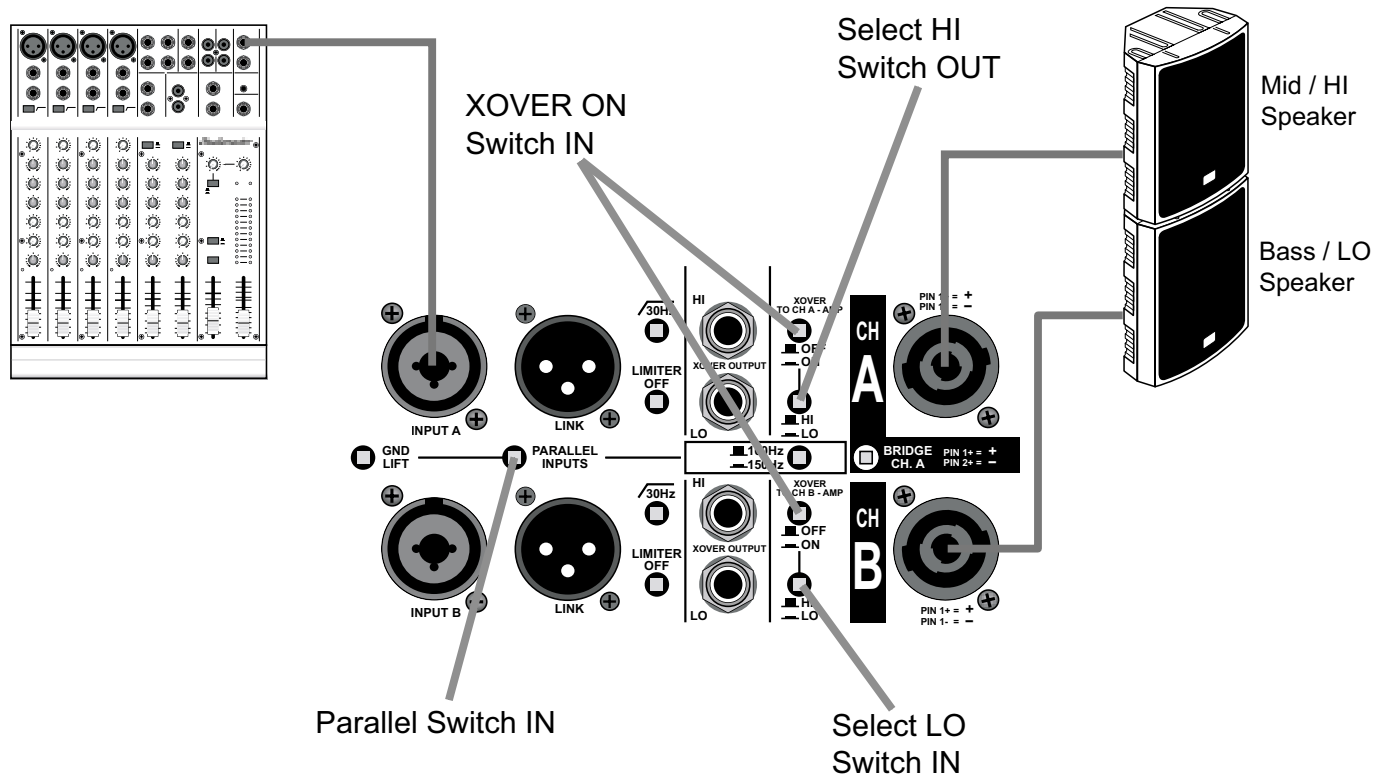

### 4 Stereo Bi-amp

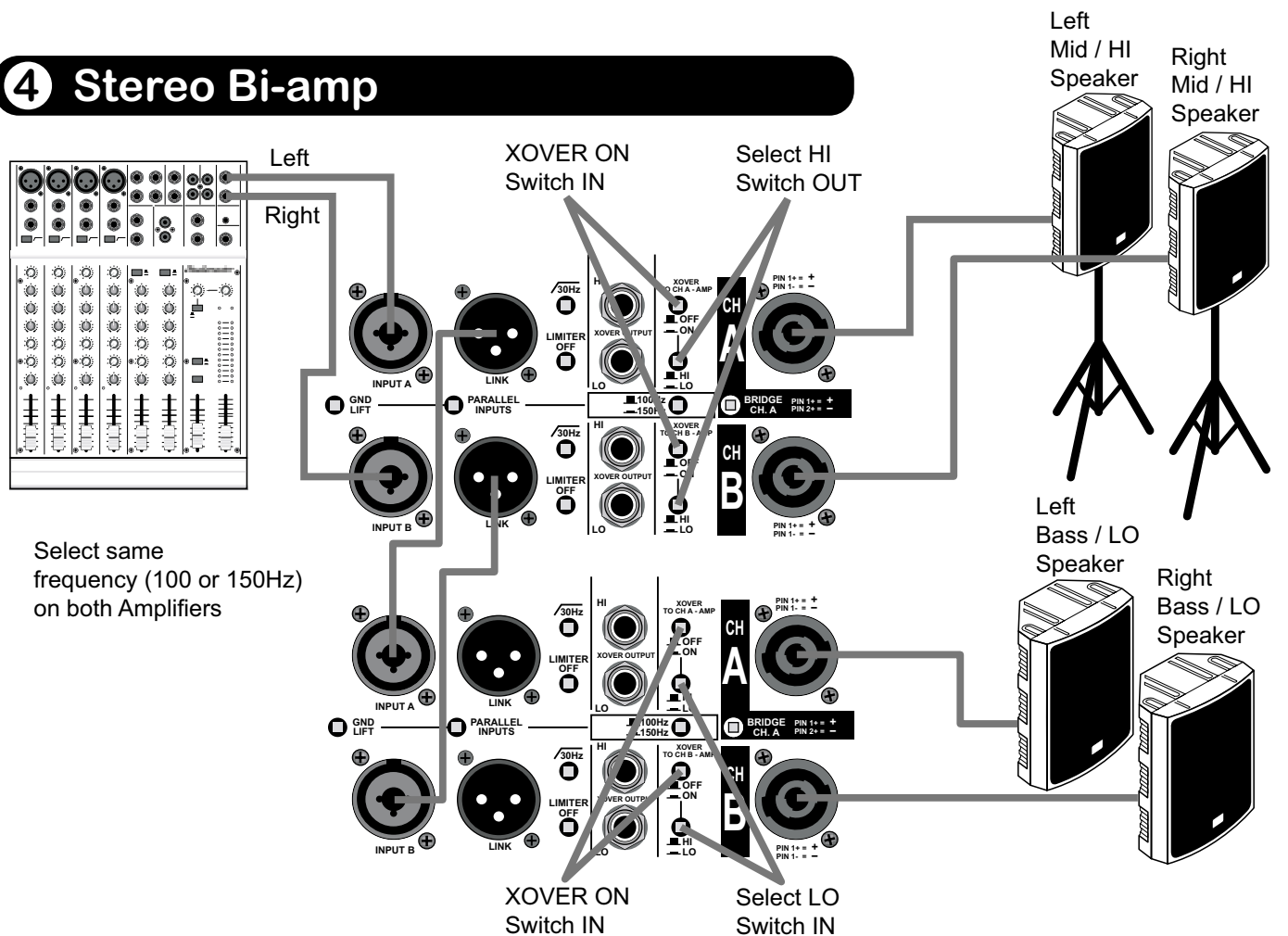

## 5 2-way Monitor Mix

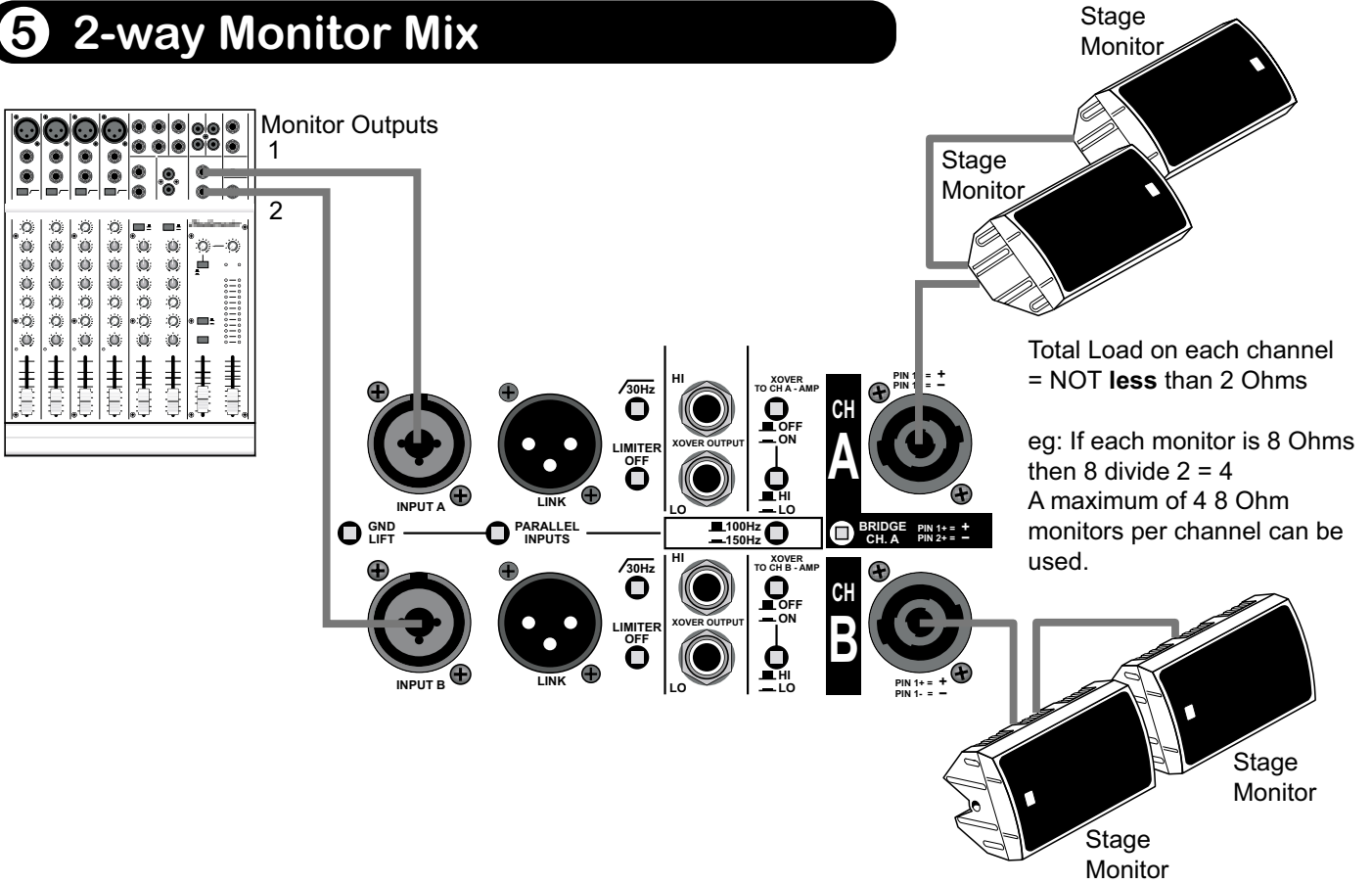

## 6 Stereo Bi-amp with Mono Sub Bass

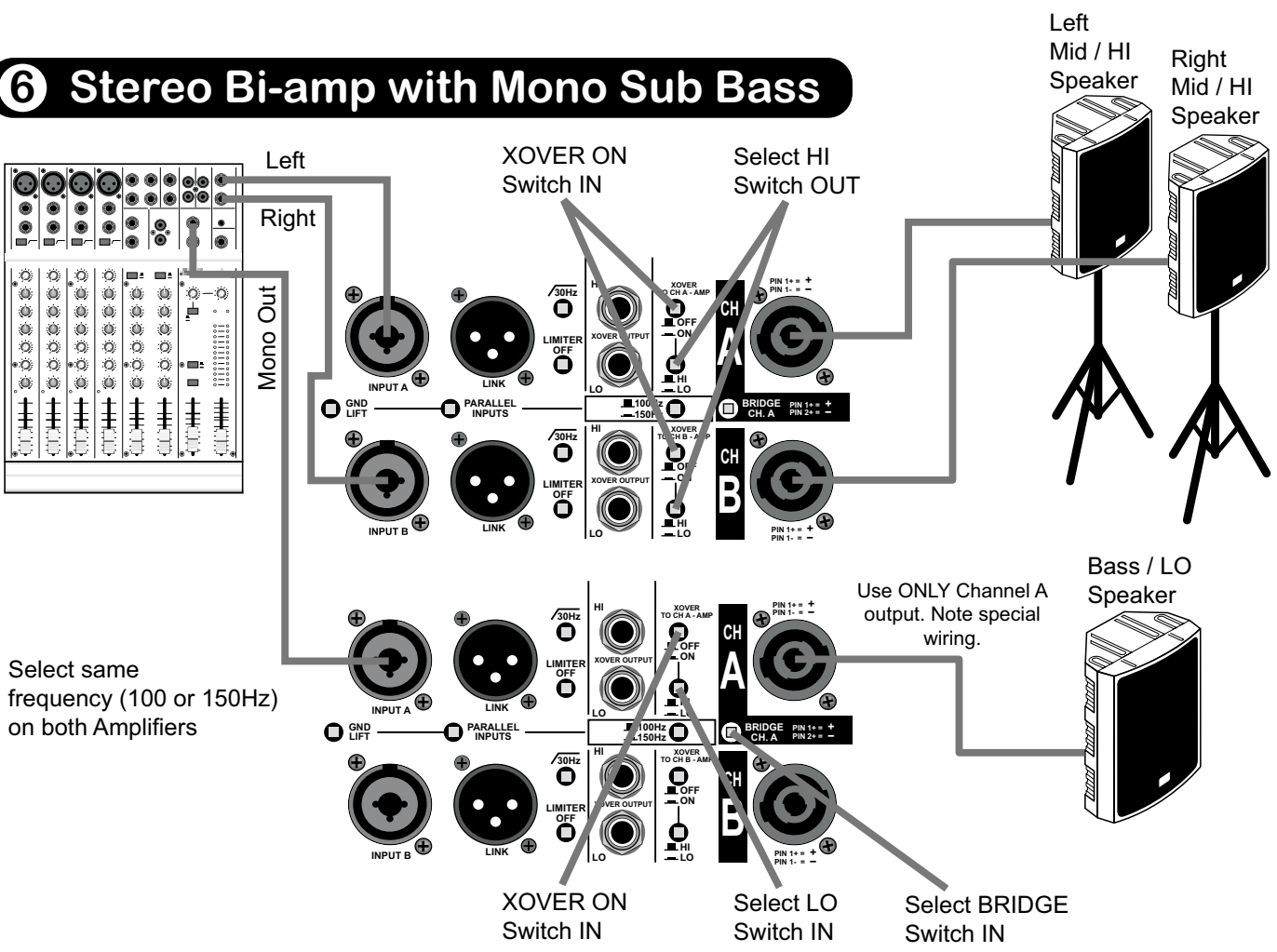



**7 2-way Stereo with additional Amplifiers**

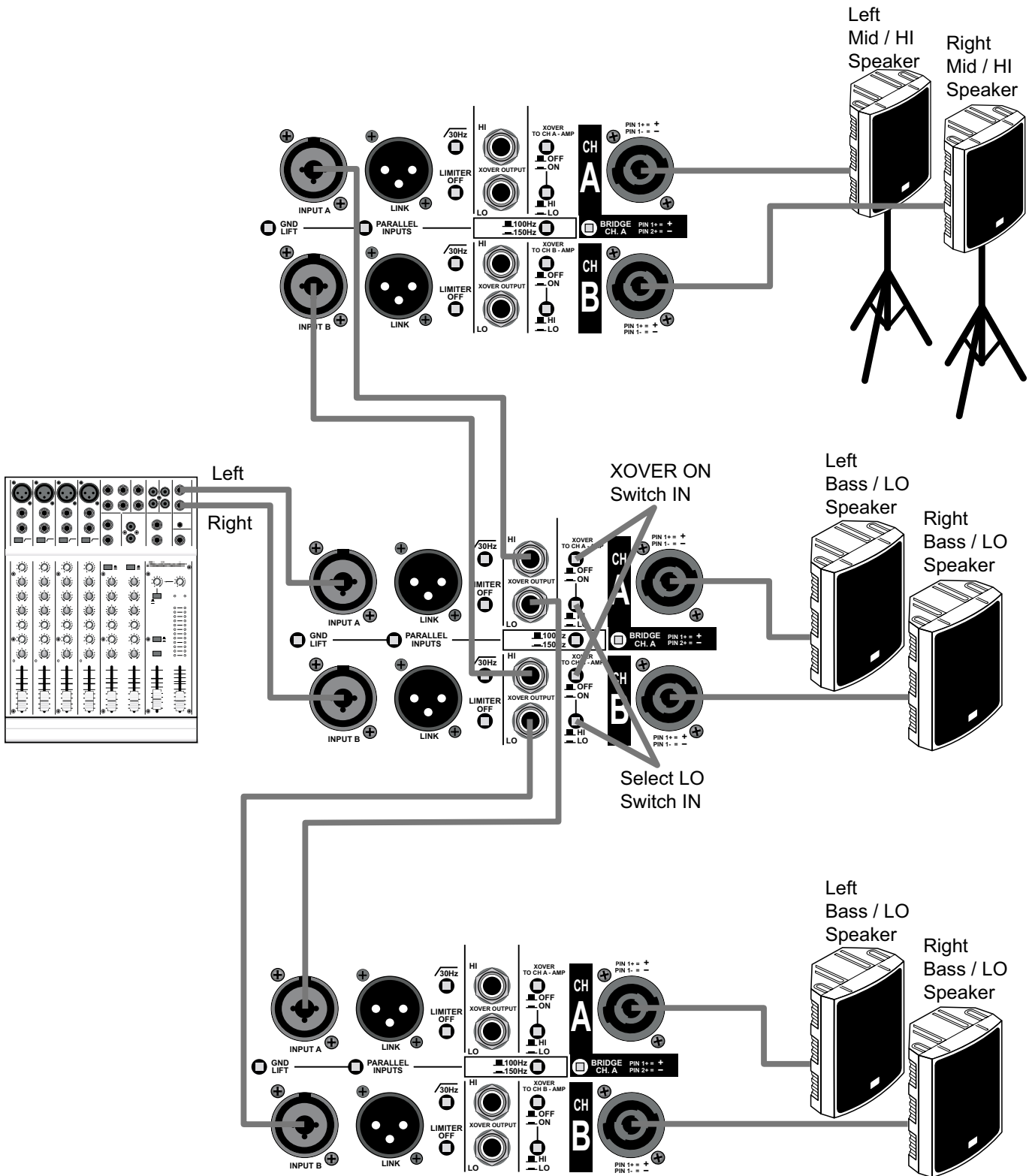





# *Studiomaster*

---

by RSD

**Recording Studio Design Limited**  
7 Eden Way, Pages Industrial Park  
Leighton Buzzard, Bedfordshire LU7 4TZ UK  
Tel : +44 (0)1525 217111 Fax : +44 (0)1525 378466  
email : enquiries@studiomaster.com

**[www.studiomaster.com](http://www.studiomaster.com)**

In Accordance with our progressive product development, Studiomaster / Recording Studio Design reserve the right to change features and specifications without prior notice.