

MICROPHONES / HAND-HELD MICROPHONE / DYNAMICS

FDM-9081-B

HAND-HELD MICROPHONE



- ✓ High quality for live voice
- ✓ Low handling noise
- ✓ Metal body
- ✓ On/off switch
- ✓ With accessory cable for connection to XLR inputs.



+ Info:
<https://fonestar.com/FDM-9081-B>

ESPECIALLY RECOMMENDED IN:



Retail



Offices



Hotels



All sectors

DESCRIPTION

Hand-held microphone. Microphone for clear voice pick-up. Very handy metal body and slim design. Off switch for quick sound cut-off. Excellent sound quality. Suitable for general and professional use. Singers, live performances, announcers, etc.

TECHNICAL CHARACTERISTICS

FEATURES	High-quality dynamic capsule. Unidirectional directivity pattern with feedback suppression. Suspension system with low handling noise. High quality for live voice.
CAPSULE	Unidirectional dynamic
RESPONSE	50-13,000 Hz
SENSITIVITY	-53 dB (V/Pa)
IMPEDANCE	600 Ohm
SWITCH	On/off slider
BODY	Cast metal, streamlined finish
CONNECTOR	XLR male.
WEIGHT	0.3 kg
ACCESSORIES	3 m balanced cable with XLR female to XLR male connectors Microphone holder Carry bag



+ Info:

<https://fonestar.com/FDM-9081-B>

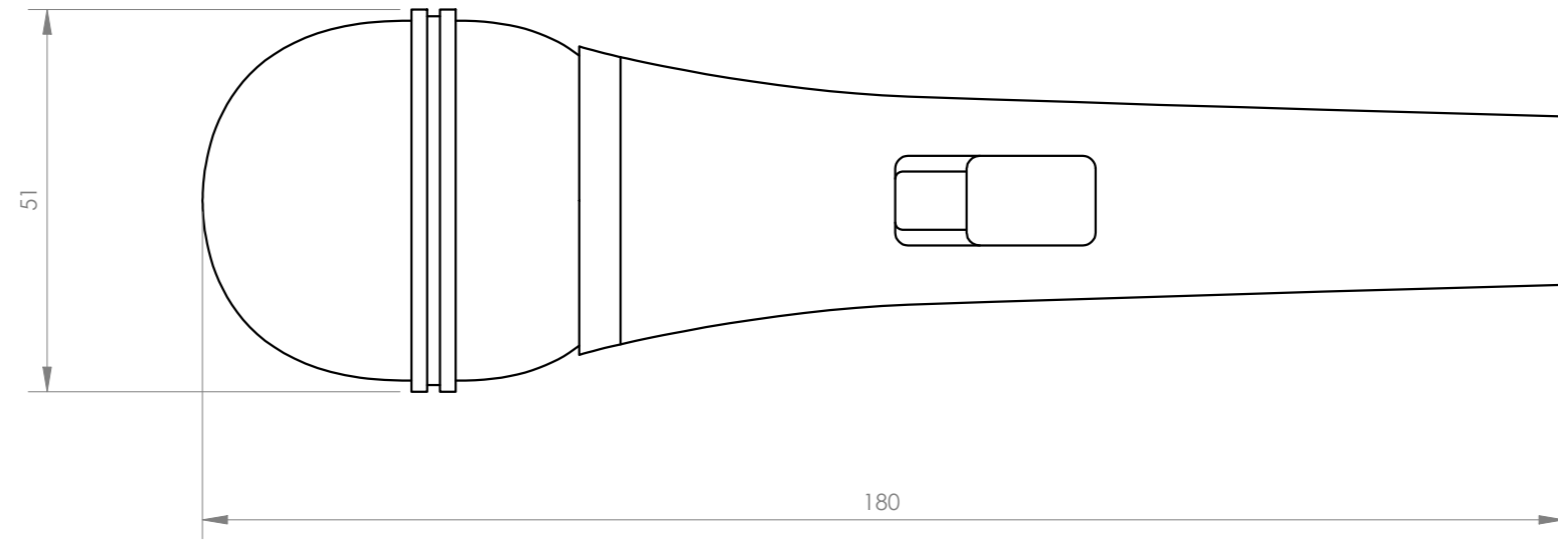

FDM-9081-B

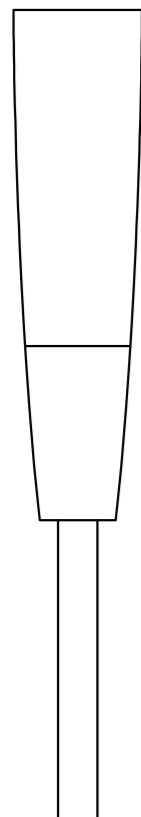

FDM-9081-D

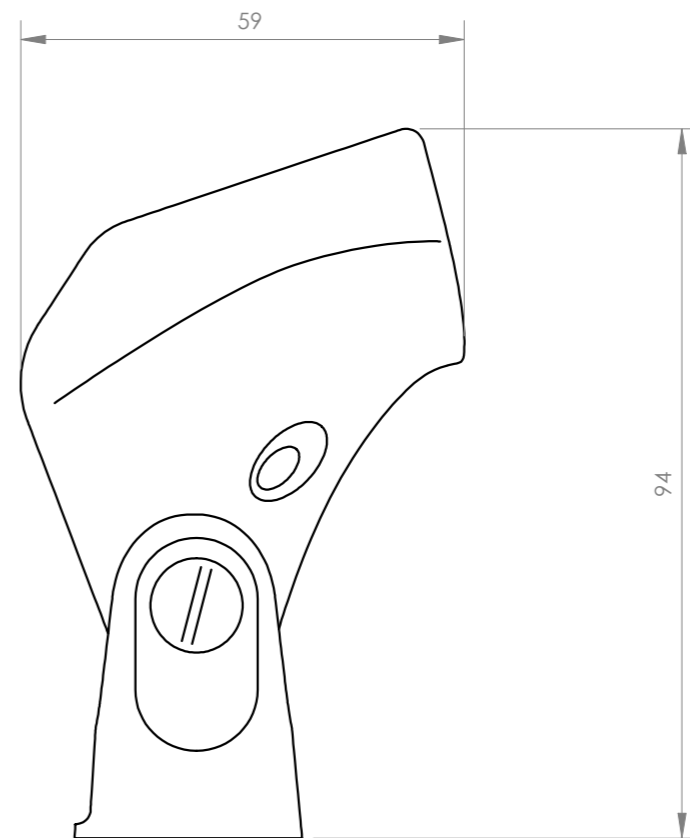
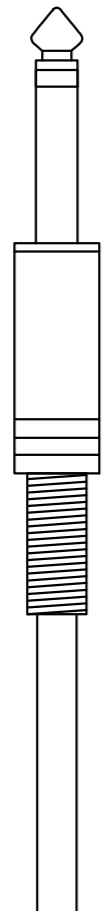

FONESTAR	Model	Description	Units	Scale
	FDM-9081-B+FDM-9081-D	HAND-HELD MICROPHONE	mm	1:1