

PUBLIC ADDRESS / SPEAKERS / SOUND PROJECTORS

# PF-26T

UNIDIRECTIONAL SOUND PROJECTOR



IP55

- ✓ Excellent sound quality
- ✓ Excellent finish and elegant design
- ✓ IP-55 protection



+ Info:

<https://fonestar.com/PF-26T>

ESPECIALLY RECOMMENDED IN:



Factories



Education



Transport Stations



All sectors

## DESCRIPTION

100 V line sound projector Sound projector with great features, design and construction. Its features make it very suitable for public address installations where messages or background music need to be played. It is a durable and low maintenance loudspeaker. It is constructed of ABS with weatherproof housing and weatherproof materials, which guarantees its integrity and operation outdoors. It has a 100 V line transformer for installations with long cable runs. It offers a clear sound and great frequency response, perfect for public address and music ambience applications. With a wide coverage angle that allows to cover a large area and a power that makes the sound reach a great distance. For public address and background music applications in 100 V line installations in shopping centres, schools, sports facilities, industrial buildings, shopping streets, car parks, etc.

## TECHNICAL CHARACTERISTICS

FEATURES	Sound projector with 100 V line transformer.
POWER	30 W maximum, 20 W RMS
LOUDSPEAKERS	6 ½" varnished cardboard cone
RESPONSE	170-16,000 Hz
IMPEDANCE	20 W RMS@100V (500 Ohm) 10 W RMS@100V (1.000 Ohm) 5 W RMS@100V (2.000 Ohm)
SENSITIVITY	92 dB at 1 W/1 m
MAXIMUM SOUND PRESSURE	105 dB at max. W/1m
DISPERSION	170°@1kHz, 90°@2kHz, 45°@4kHz (-6 dB)
PROTECTIONS	IP-55 in compliance with 60529
MATERIAL	ABS. Hermetic casing Aluminium mount and grille Stainless steel screws
TEMPERATURE RANGE	-25°C ~ 55°C
COLOUR	White (RAL 9016)
DIMENSIONS	170 mm Ø x 245 mm depth
WEIGHT	1.75 kg
ACCESSORIES	Adjustable fixing mount



+ Info:

<https://fonestar.com/PF-26T>

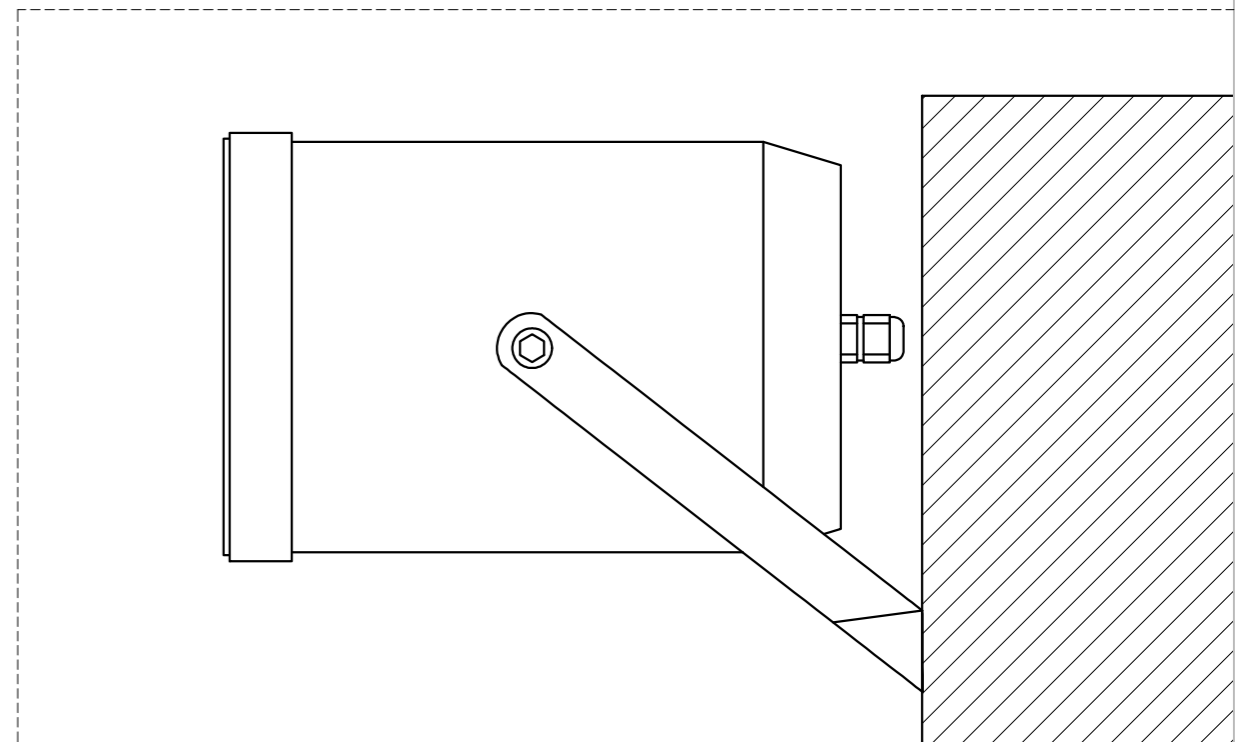
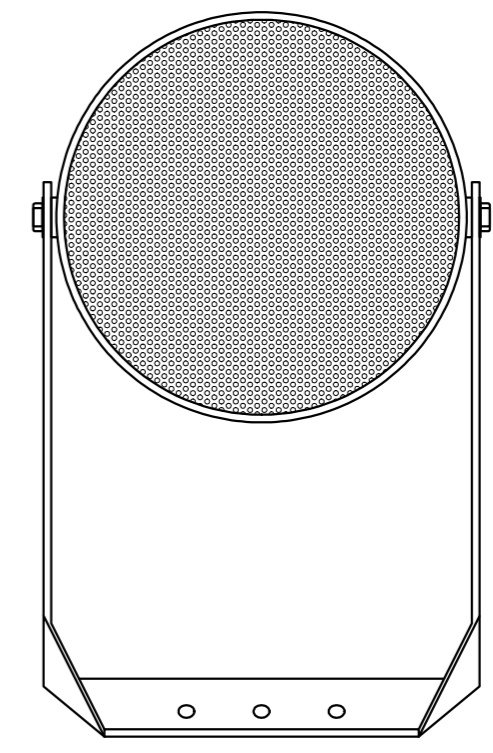
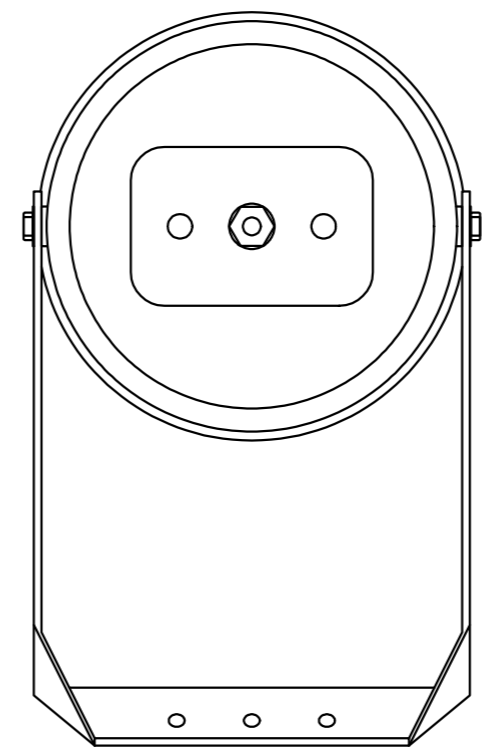
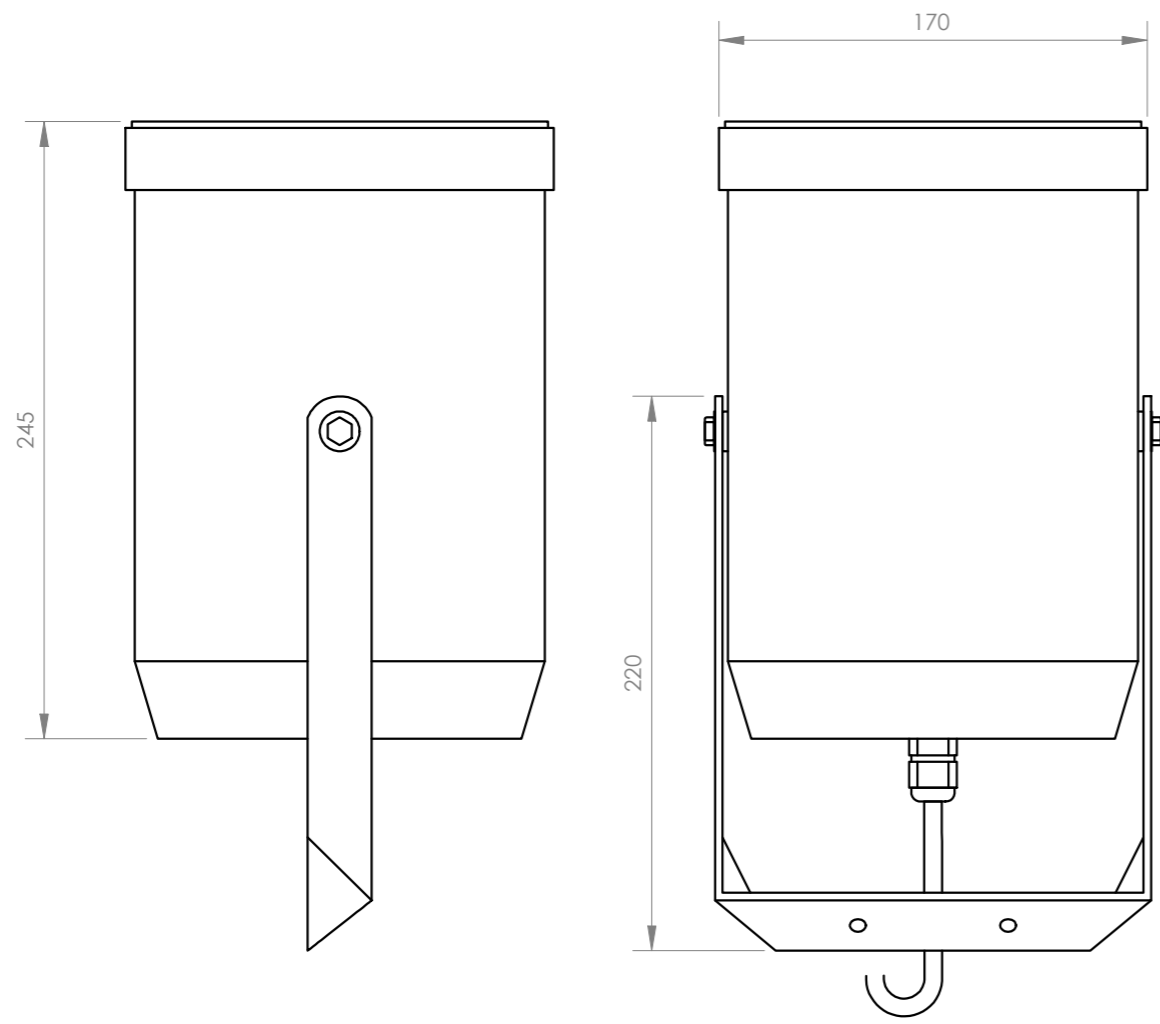

<b>FONESTAR</b>	Model	Description	Units	Scale
	PF-26T	UNIDIRECTIONAL SOUND PROJECTOR	mm	1:3