

PUBLIC ADDRESS / SPEAKERS / CEILING

SKY-6T

100 V LINE TRANSFORMER CEILING SPEAKER



IP44



SALT MIST RESISTANCE



3-POINT ANCHORAGE



ANTI-DROP SYSTEM



TAP-LOCK TERMINALS



TURN-LOCKABLE GRILLE

- ✓ Low profile aluminium grille
- ✓ Highly conductive quick-connect terminals
- ✓ Anti-fall system for installation assistance
- ✓ Stable ceiling mounting brackets



+ Info:
<https://fonestar.com/SKY-6T>

ESPECIALLY RECOMMENDED IN:



Hospitality



Retail



Hotels



All sectors

DESCRIPTION

100 V line transformer ceiling loudspeaker

Design by Fonestar products are born from in-depth research and active customer feedback, turning their needs into competitive solutions.

The innovative SKY series of ceiling loudspeakers is full of details that make them special. Carefully tailored to reproduce the best sound and meet the needs of audio installations. We have created the SKY series of ceiling loudspeakers to offer a unique solution.

We provide improvements in the installation, a defined sound for background music and sound reinforcement. We have carefully selected the materials and components to obtain the best performance and reliability, with an amazing sound. Rounding up our idea of the best ceiling loudspeaker.

The grille is the only visible part of the loudspeaker once installed in the ceiling, so we have designed it to have minimal visual impact, frameless and a low profile. It is built in aluminium with high resistance liquid paint. No rust stains will appear and it will keep its original appearance. It can be customised by removing the removable logo and it can be painted.

The connection of the cables is made with innovative quick-connect terminals, which offer an instant connection with a secure anchoring system and maximum conductivity.

The ceiling loudspeaker has an anti-fall system to aid installation, allowing the loudspeaker to be positioned prior to final installation with the ceiling fixing brackets. In addition, it has a hook for speaker attachment and a safety cable.

It has a very stable ceiling attachment system with three brackets and a worm screw adjustment system. Installation is quick and easy and provides a firm and secure hold.

The main component for sound playback is the speaker, with a heavy-duty polypropylene diaphragm and a double cone, which improves the frequency response and high-frequency dispersion. Once installed the loudspeaker has an IP-44 dust and water ingress protection rating. Splashing will not affect the performance of the loudspeaker.

For background music and sound reinforcement systems in shopping centres, shops, hotels, hospitals,



+ Info:

<https://fonestar.com/SKY-6T>

business centres, restaurants, etc.

TECHNICAL CHARACTERISTICS

FEATURES	<p>100 V line transformer ceiling loudspeaker.</p> <p>Low profile frameless grille, constructed from rust resistant aluminium. Detachable, turn-lockable. The logo can be removed and the speaker can be painted.</p> <p>Fast connection terminals and high conductivity.</p> <p>Anti-fall system for installation assistance.</p> <p>Hook for safety cable.</p> <p>Stable, worm-gear ceiling brackets.</p> <p>Protection against dust and water.</p>
POWER	<p>15 W RMS</p> <p>20 W MAX.</p>
SPEAKER	6" polypropylene double cone diaphragm
RESPONSE	<p>55-18,000 Hz @ -10 dB</p> <p>85-7,500 Hz @ -3 dB</p>
IMPEDANCE	<p>15 W RMS@100 V (666 Ohm)</p> <p>10 W RMS@100 V (1,000 Ohm)</p> <p>5 W RMS@100 V (2,000 Ohm)</p>
SENSITIVITY	88 dB @ 1 W/1 m
SOUND PRESSURE	<p>97 dB @ max. W/1m Continuous</p> <p>100 dB @ max. W/1m Peak</p>
COVERAGE ANGLE	H/V (-6 dB): 150°@500Hz, 150°@1kHz, 90°@2kHz, 60°@4kHz
PROTECTIONS	<p>IP-44 in compliance with EN 60529</p> <p>EN ISO 9227:2006 Neutral Salt Spray Test</p>
MATERIAL	<p>ABS (UV resistant)</p> <p>Liquid paint aluminium grille</p>
CONNECTORS	<p>Highly conductive quick-connect terminals</p> <p>For 0.4 ~ 4 mm² cross section cable</p>
OPERATION TEMPERATURE	5°C ~ 40°C
STORAGE TEMPERATURE	2°C ~ 50°C
MAXIMUM HUMIDITY	0.9
COLOUR	White (RAL 9003)
DIMENSIONS	<p>Total loudspeaker: 249 mm Ø x 85 mm height</p> <p>Grille section: 5 mm</p> <p>Recessed height: 80 mm</p> <p>Installation hole: 219 mm Ø</p> <p>Maximum ceiling thickness: 30 mm</p>
WEIGHT	0.95 kg
ACCESSORIES	Installation template



+ Info:
<https://fonestar.com/SKY-6T>

SPL vs Frequency

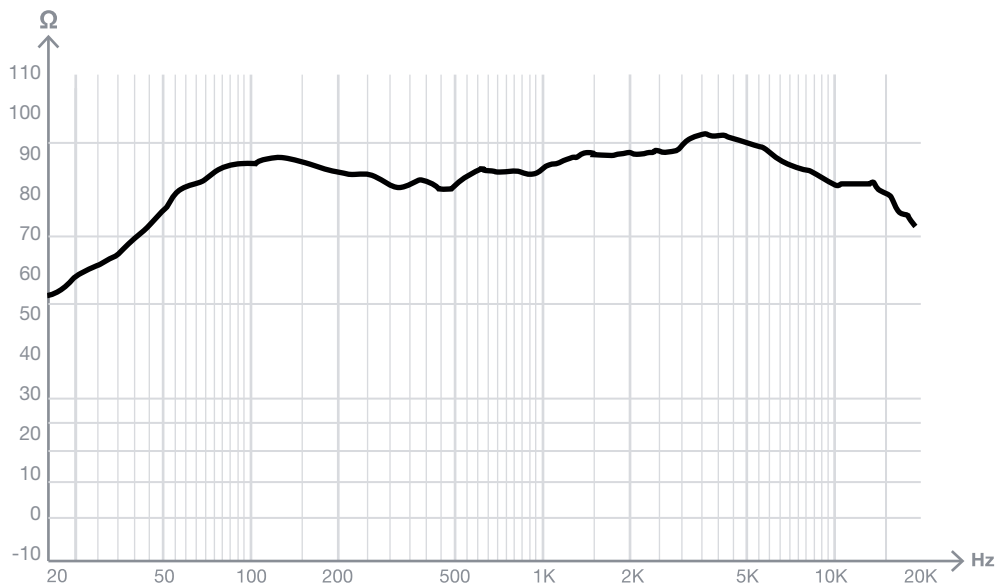

SPL vs Angle

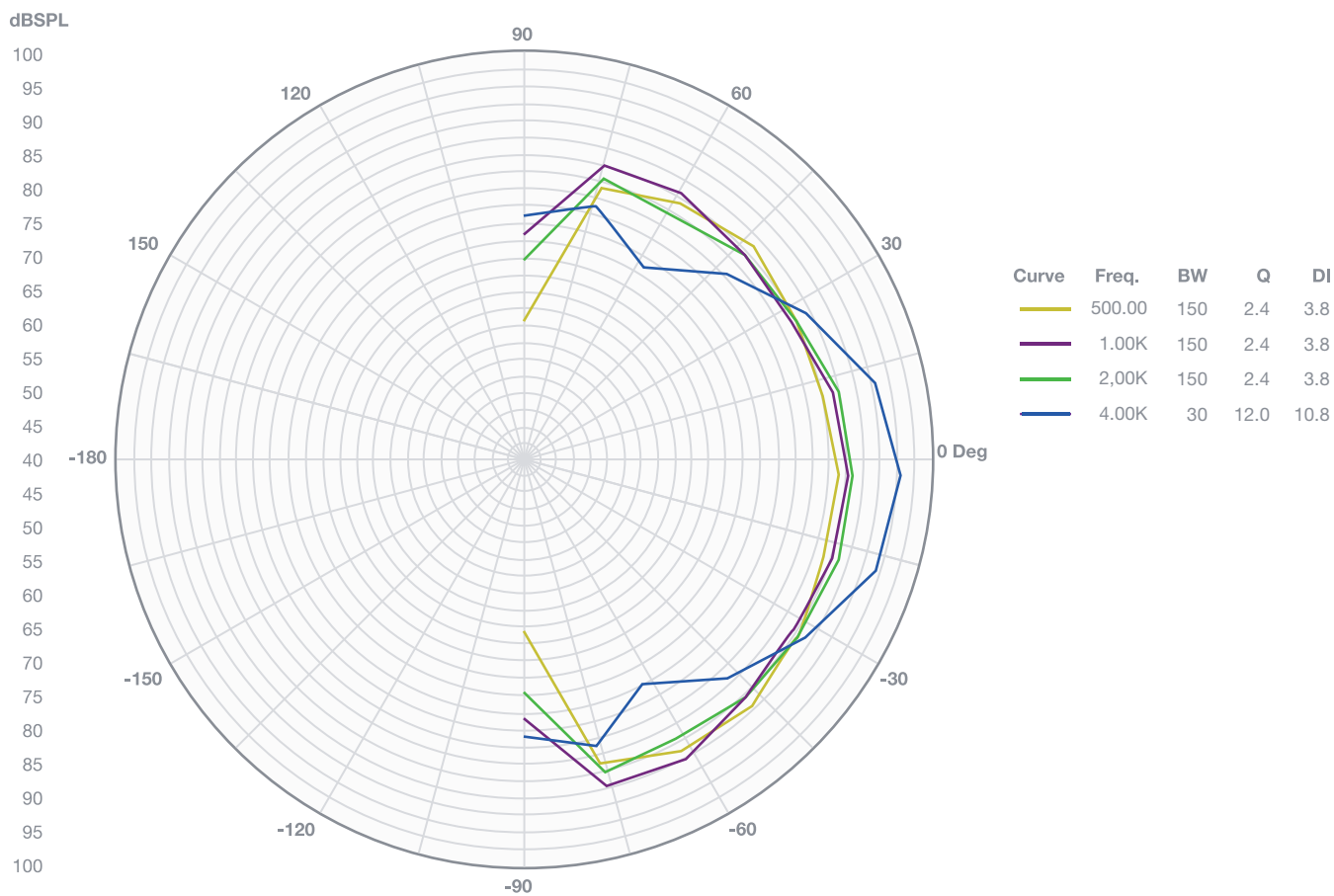

+ Info
<https://fonestar.com/SKY-6>



● ↕ Impedance vs Frequency

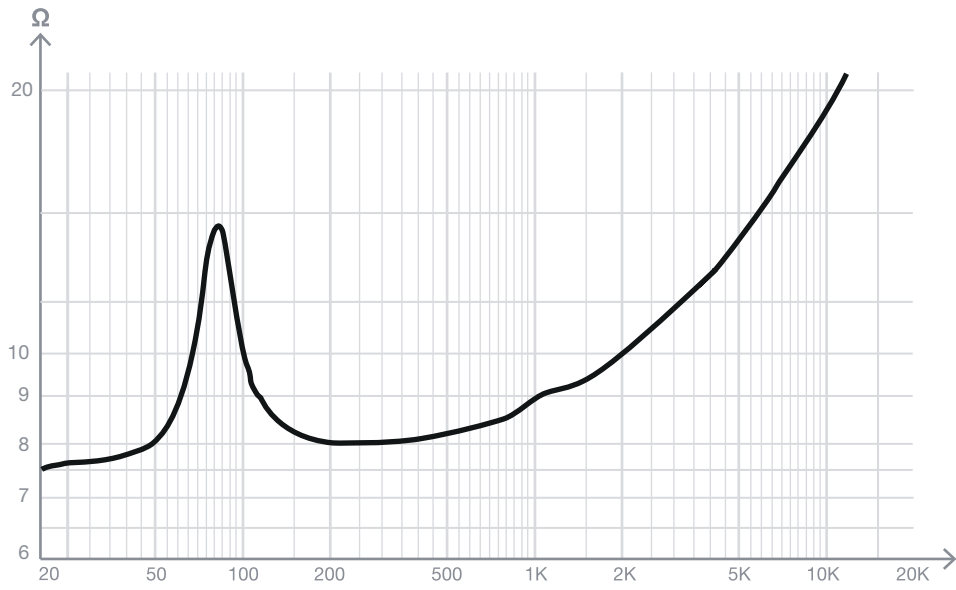

+ Info
<https://fonestar.com/SKY-6>

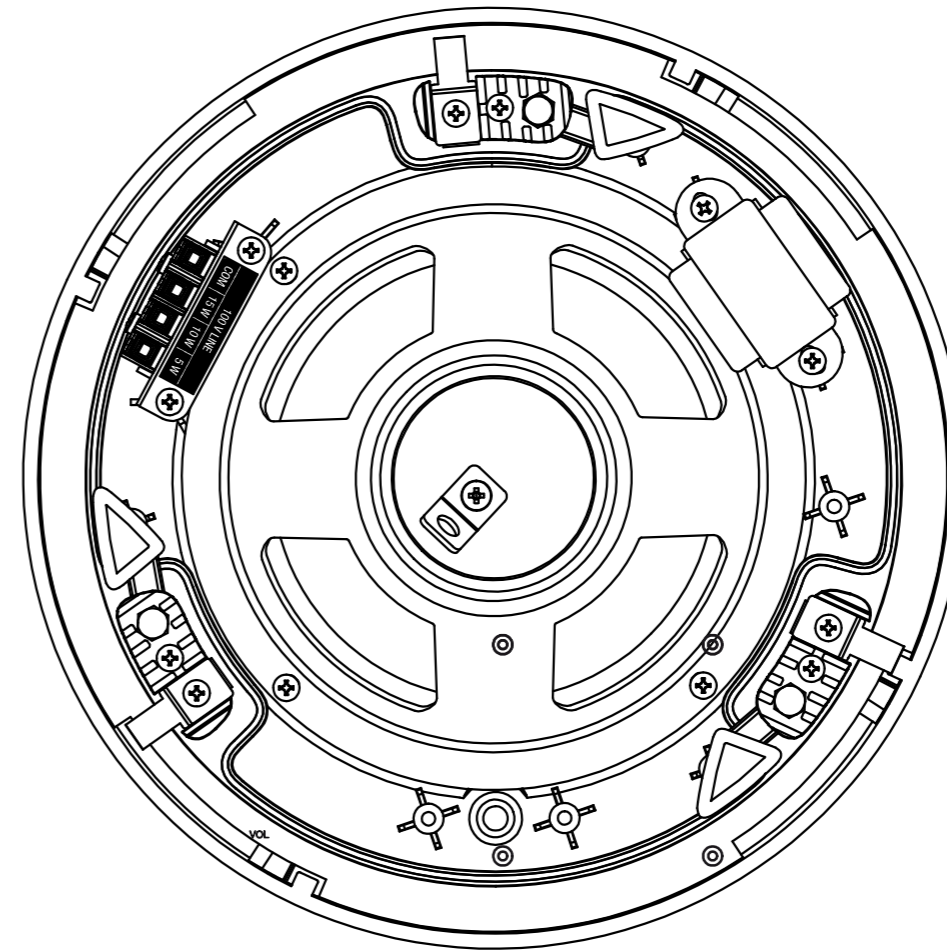
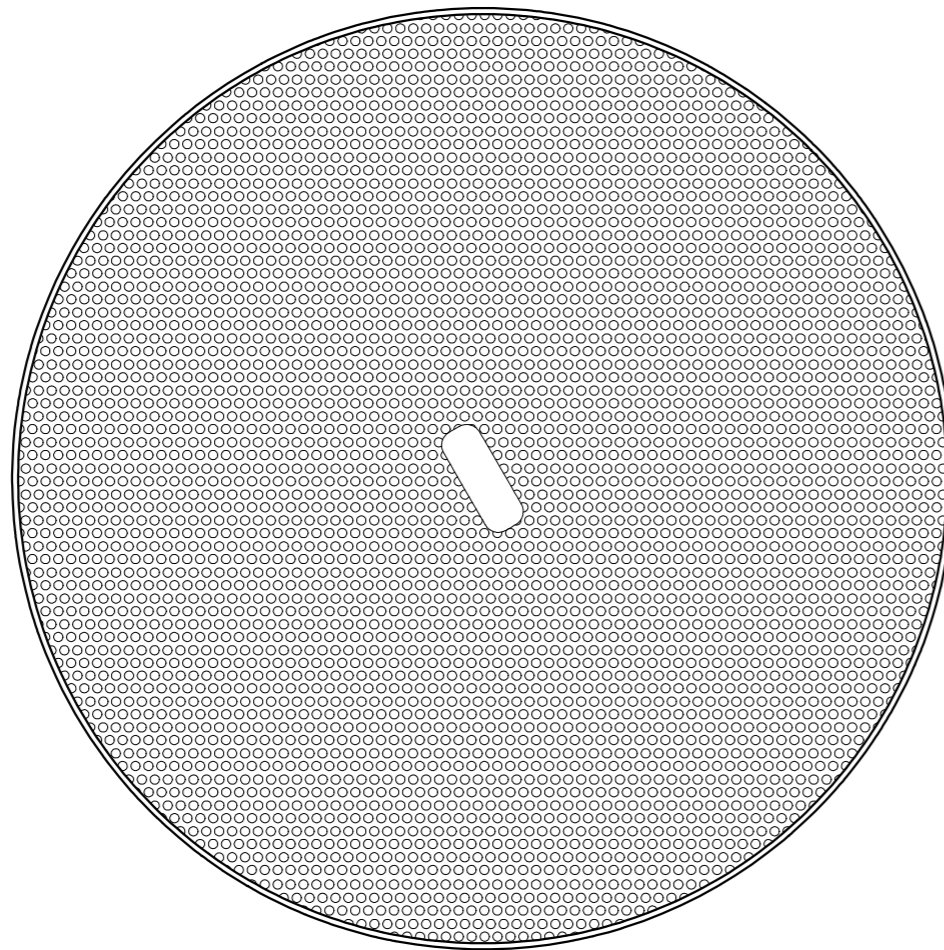
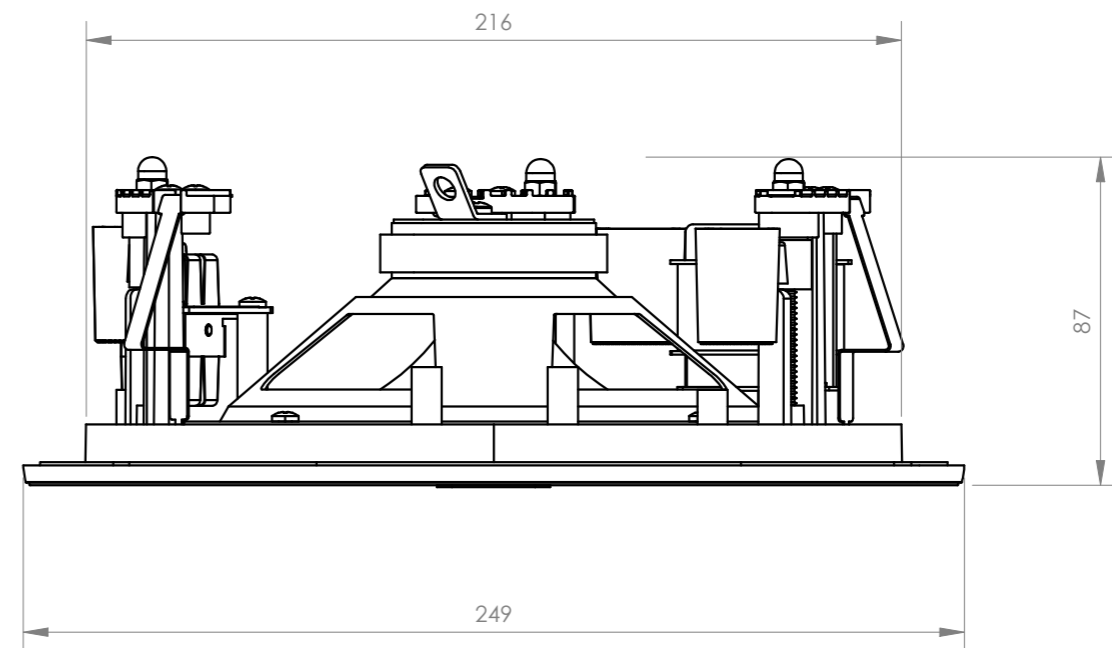

FONESTAR	Model	Description	Units	Scale
	SKY-6T	100 V LINE TRANSFORMER CEILING LOUDSPEAKER	mm	1:2