

SISTEMAS Y CONTROL / SISTEMAS DE ZONAS / ANALÓGICO

ZONE-6

6-ZONE OUTPUT SWITCHING UNIT



- ✔ Transform your installation from independent zones to a zone system.
- ✔ Zone contact closures for activation of attenuators or connection to alarm systems
- ✔ Easy to install and operate zone system



+ Info:
<https://fonestar.com/ZONE-6>

ESPECIALLY RECOMMENDED IN:



Factories



Education



Social and health centers



Hotels

DESCRIPTION

6-zone output switching unit Fonestar has designed a 6-zone output system that is easy to install and manage, with the aim of transforming your old installation into a system of independent zones. By means of the ZONEMIC-6 zone microphone you can give independent announcements to the zones of your choice. In addition, each time a warning is given, a contact closure shall be activated at the output of the corresponding zone. This shall allow the system to be connected to volume controllers or any other external systems, such as alarm systems, that are activated by contact closure. Among its multiple applications, commercial installations that require different audio for each of the zones stand out.

TECHNICAL CHARACTERISTICS

FEATURES	6-zone output switching unit. Connection to the ZONEMIC-6 paging microphone, connection of up to 4 microphones. Possibility of activating the priority in attenuators by contact closure when giving warnings from the ZONEMIC-6 microphone. Status indicator lights for each zone.
INPUTS	1 ZONEMIC-6 microphone with zone selector and recorded messages, RJ45
OUTPUTS	6 x balanced lines, euroblock 500 mV
POWER SUPPLY	230 V AC 50/60 Hz, 2.9 W
DIMENSIONS	262 x 44 x 128 mm depth
WEIGHT	1 kg
OPTIONAL	ZONEMIC-6: Zone microphone with recorded messages



+ Info:
<https://fonestar.com/ZONE-6>

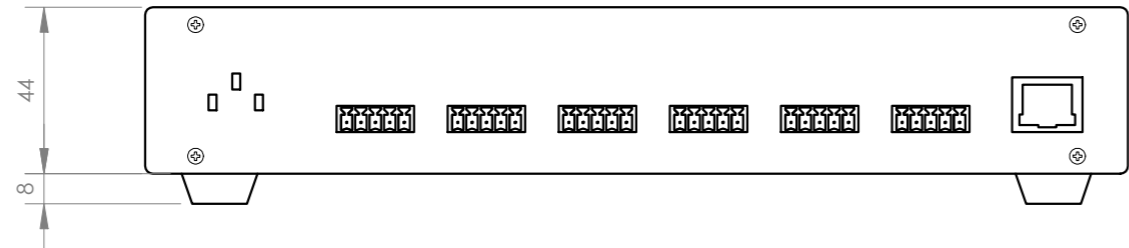
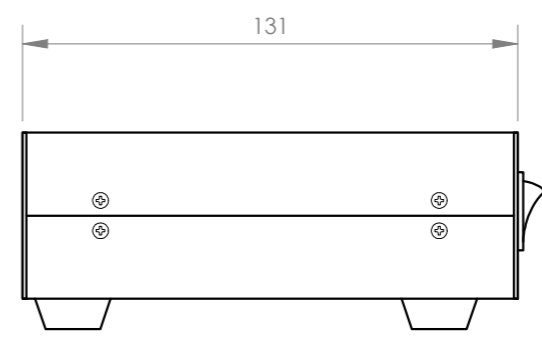
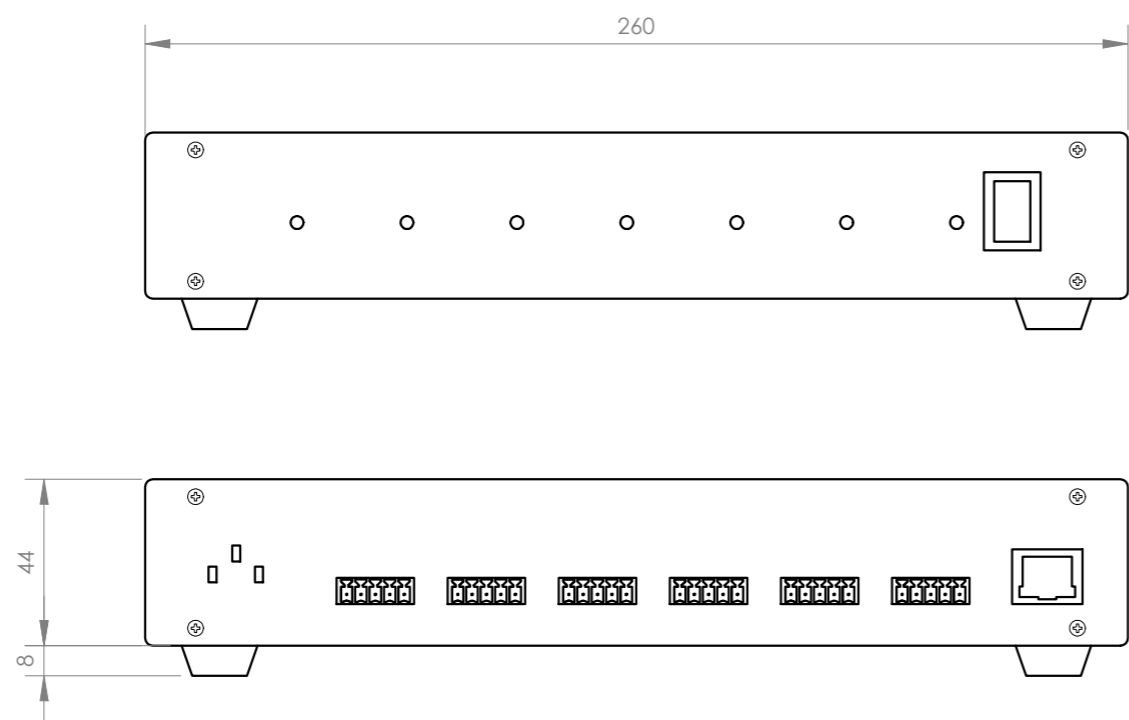

FONESTAR	Model	Description	Units	Scale
	ZONE-6	ZONEMIC-6_AUTOCAD_20231110	mm	1:2